

Chapter 4

MICROSWITCHES, DOWTY, 1831Y SERIES

LIST OF CONTENTS

| | Para. | | Para. |
|-------------------------------------|-------|--|-------|
| <i>Introduction</i> | 1 | <i>Sealed switches</i> | 19 |
| Description | 4 | Servicing | 24 |
| <i>Switch reference code</i> | 12 | Testing | |
| <i>Operation</i> | 13 | <i>Millivolt drop test</i> | 25 |
| Installation | 14 | <i>Insulation resistance test</i> | 26 |
| <i>Weatherproof switches</i> | 16 | | |

LIST OF ILLUSTRATIONS

| | Fig. | | Fig. |
|--|------|---|------|
| <i>Microswitch, Type 1831Y with weatherproof grommet and shroud</i> | 1 | <i>6 B.A. terminal arrangement</i> | 4 |
| <i>Sectional view of microswitch</i> | 2 | <i>Circuit diagram</i> | 5 |
| <i>S.B.A.C. terminal arrangement</i> | 3 | <i>Installation, sealed switches</i> | 6 |
| | | <i>View of various types of cable grommets</i> | 7 |

LIST OF TABLES

| | Table |
|--|-------|
| <i>"Downmic" switches, Mk. 101 to 104</i> | 1 |

LIST OF APPENDICES

| | App. |
|---|------|
| <i>Microswitch, Type 1831Y series (Conversion table)</i> | 1 |

LEADING PARTICULARS

| | |
|--|--------------------------------|
| <i>Microswitch, Type 1831Y series</i> | <i>Ref. No. see Appendix 1</i> |
| <i>Voltage</i> | 28V d.c. |
| <i>Operational ceiling</i> | 60,000 ft |
| <i>Temperature range</i> | -40 to +70 deg. C. |
| <i>Temperature range (special application)</i> | -65 to +150 deg. C. |
| <i>Pre-travel (in.)</i> | 0.003 min. to 0.086 max. |
| <i>Over travel (in.)</i> | 0.50 min. |
| <i>Length of travel (in.)</i> | 0.55 nominal |
| <i>Load to operate (lb.)</i> | 8 ± 1.5 |
| <i>Load at maximum travel (lb.)</i> | 20 max. |
| <i>Differential travel (in.)</i> | 0.02 max. 0.006 min. |
| <i>Safe overload (lb.)</i> | 1500 |
| <i>Microswitch with cable grommet</i> | |
| <i>Maximum overall dimensions (in.):—</i> | |
| <i>with weatherproof grommet (six entry, short)</i> | 2.81 × 1.17 × 2.84 |
| <i>with weatherproof grommet (six entry, long)</i> | 2.81 × 1.17 × 3.28 |
| <i>with weatherproof grommet (single entry)</i> | 2.81 × 1.17 × 3.36 |
| <i>with special grommet (long type)</i> | 2.81 × 1.17 × 7.52 |
| <i>Microswitch without grommet</i> | 2.81 × 1.17 × 1.83 |

RESTRICTED

Introduction

1. The microswitch, Type 1831Y, incorporates a two-pole, change-over contact arrangement with a spring-return to the unoperated position. The contacts are operated by a rubber-shrouded, spring-loaded plunger, a positive make and break action being obtained by the use of a permanent magnet at each position, acting on an insulated armature.

2. The microswitches covered in this chapter are of a similar design electrically, but differ in terminal arrangements and weatherproof grommets, to suit particular applications.

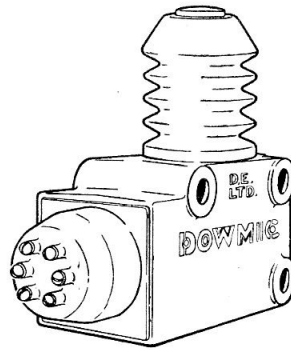
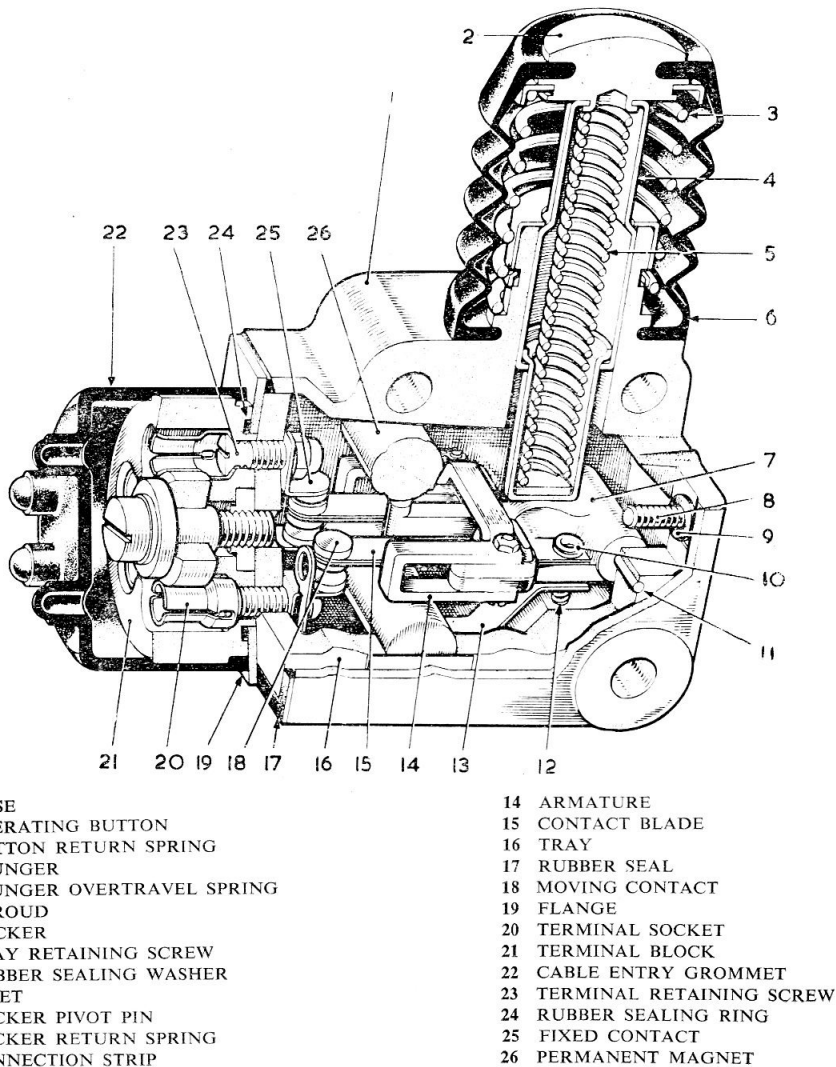

Fig. 1. Microswitch, Type 1831Y with weatherproof grommet and shroud



- | | |
|-----------------------------|-----------------------------|
| 1 CASE | 14 ARMATURE |
| 2 OPERATING BUTTON | 15 CONTACT BLADE |
| 3 BUTTON RETURN SPRING | 16 TRAY |
| 4 PLUNGER | 17 RUBBER SEAL |
| 5 PLUNGER OVERTRAVEL SPRING | 18 MOVING CONTACT |
| 6 SHROUD | 19 FLANGE |
| 7 ROCKER | 20 TERMINAL SOCKET |
| 8 TRAY RETAINING SCREW | 21 TERMINAL BLOCK |
| 9 RUBBER SEALING WASHER | 22 CABLE ENTRY GROMMET |
| 10 RIVET | 23 TERMINAL RETAINING SCREW |
| 11 ROCKER PIVOT PIN | 24 RUBBER SEALING RING |
| 12 ROCKER RETURN SPRING | 25 FIXED CONTACT |
| 13 CONNECTION STRIP | 26 PERMANENT MAGNET |

Fig. 2. Sectional view of microswitch

RESTRICTED

3. With the introduction of the Mk. 101 to 200 range of 1831Y microswitches a further series of tests is being undertaken with a view to reassessing all marks of 1831Y switches. The 28.5 volt d.c. series of tests have been completed (i.e. 8 amps per pair of contacts with a resistive load and 5 amps per pair of contacts with an inductive load of 0.15 henry) but, in view of this reassessment, it would be more satisfactory to omit ratings for the a.c. voltages until the new tests are available.

DESCRIPTION

4. The microswitch, of which a general view showing a six entry grommet fitted, is given in fig. 1, is a double-pole, change-over type, with a quick make and break action. The switch is fitted with heavy duty contacts, having a minimum separation of 0.025 in., and is designed for use in a.c., or d.c. circuits. The Mk. 101 to 200 range have only been tested on 28.5 volt d.c. supply, see para. 3.

5. The bottom of the switch casing accommodates a Bakelite tray, to the outer face of which are secured a metal flange and a terminal block by means of the terminal fixing screws. The same screws are used to secure four fixed contacts, arranged in pairs, to the inner face of the tray and to connect them to the terminals, (fig. 2).

6. Two connecting strips are similarly fixed and connected to their own terminals in the terminal block; these connecting strips follow the shape of the tray floor until just before

they terminate, then their shape allows a return spring to be fitted under the end of each strip. Two recesses in the tray locate the other end of the return springs.

7. Pivoted in the tray is a rocker sub-assembly, comprising a rocker, two laminated contact blades, and an insulated armature. The contact blades are each riveted in pairs at one end of the rocker, the rivet heads being designed to act as electrical contacts for connecting strips positioned immediately below them. Contacts at the other end of each blade, operate between the fixed contacts.

8. Two magnets are positioned in the tray, one above and one below the armature, the relevant magnet attracting the insulated armature during operation, so that positive switching actions are obtained. The magnets also act as arc blow-outs.

9. For electrical purposes the switches are provided with either six sockets accepting S.B.A.C. type crimped-on ferrules locked by one 4. B.A. screw (fig. 3), or six 6 B.A. shrouded terminal screws (fig. 4). When the S.B.A.C. type terminal arrangement is used, spare ferrules should be fitted in the unused terminal positions to ensure that all terminals are secure when the centre screw is tightened.

10. The weather sealed switches in the Mk. 1 to 100 range are Mk. 9, 10, 19 and 23, and the sealed versions of Mk. 101 to 200 are indicated by the letters D or DT placed after the mark number in the reference code in Table 1.

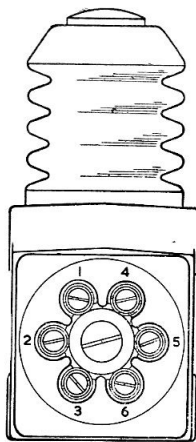

Fig. 3. S.B.A.C. terminal arrangement

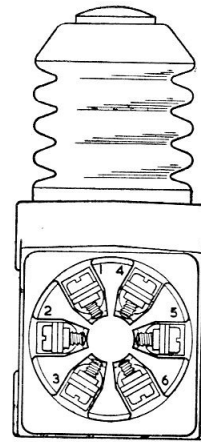

Fig. 4. 6 B.A. terminal arrangement

RESTRICTED

11. If the switch is required to work in extremes of temperature, i.e. 70 deg.C to 150 deg.C., or -40 deg.C. to -65 deg.C., special construction is required. The extreme temperature range of the older type switches are Mk. 12 and 18, or, in the Mk. 100 to 200 versions, the switches with the letter T placed after the reference letter. The reference letter placed after the mark number indicates the type of selected cable entry grommet.

Switch reference code

12. After selecting the mark number of switch which offers the required terminations and temperature range, the cable entry grommet needed is specified by the addition of a letter suffix to the mark number, e.g. switch with 6 B.A. terminals, intended for use between the temperatures of -40 and 70 deg. C. and fitted with a weatherproof cable entry grommet would carry the reference "Downmic Mk. 102D". As shown in the illustration (fig. 7), there are ten standard cable entry grommets available, types B to F and types BT to FT. Types B to F are fitted to switches marks 101 and 102 for use in the normal temperature range, -40 to +70 deg. C, and types BT to FT are fitted to switches marks 103 and 104 for use in the extended temperature range, -65 to +150 deg. C.

Operation

13. Depression of the operating plunger compresses the spring and actuates the rocker assembly on which the moving contacts are assembled. As the plunger is depressed the spring pressure increases until the magnetic pull of the top magnet is overcome, the rocker assembly then snaps over to the bottom magnet and lower fixed contacts. On release of the operating plunger, a reverse action of the switch is obtained.

INSTALLATION

14. The switch is secured to the aircraft structure by three 2 B.A. bolts passing through the switch case. The unit may be mounted in any attitude but, to obtain the longest life, the striker should engage the centre of the switch operating button and travel in a path parallel with the axis of the switch plunger.

15. With a sliding cam, or any form of sliding striker, the angle between the striker line of thrust and the axis of the switch plunger should be as small as possible, not exceeding 15 degrees. If a roller striker, well

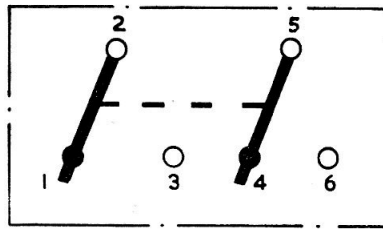

Fig. 5. Circuit diagram

supported in bearings, is used, this angular displacement may be increased to a maximum of 25 degrees.

Weatherproof switches

16. To fit a new switch fitted with a weatherproof grommet, remove the grommet and nip the extreme tips off the required sleeves. Feed the conductors through the opened sleeves causing the latter to invert. Finally pull the conductors back to re-invert the sleeves.

17. With switches fitted with S.B.A.C. terminations (fig. 2), 4A or 7A ferrules Ref. No. 5H/24 or 5H/25 respectively are to be crimped on to each conductor (or soldered, if a crimping tool is not available), and pushed home into the sockets with central screw slack. The central screw is then tightened to lock all the cable connections.

Note . . .

To ensure that all terminals are secure when the central screw is tightened, spare ferrules should be fitted in the unused terminal positions.

18. When connections are checked for security, the weather grommet should be replaced in position on the switch. Circuit connections are made at the terminals of the two-pole, change-over switch (with quick make and break action) shown in circuit diagram (fig. 5).

Sealed switches

19. Remove the grommet from the switch, pass it on to the cables, prepare the cable ends and connect them to their respective terminals. Follow the procedure detailed in para. 16. Circuit connections are made at the terminals of the two-pole, change-over switch shown in circuit diagram (fig. 5).

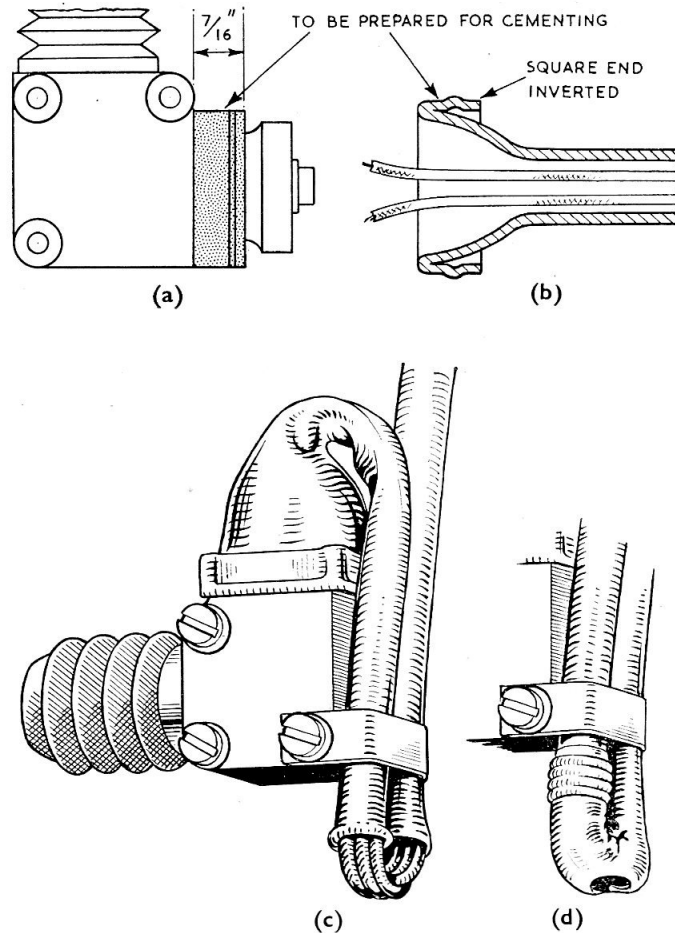

Fig. 6. Installation, sealed switches

20. Invert the square end of the grommet, then roughen the mating areas of the switch and the grommet (fig. 6a and 6b) with fine glass paper and clean with lead free gasoline, or white spirit. Allow the cleaning agent to evaporate and ensure that the prepared surfaces are not subsequently handled.

21. Apply Titebond 22 (Ref. No. 33C/1302) to the prepared surfaces of switch and grommet. Carefully mate the grommet to the switch in the correct position and roll back the square part of the grommet on to the switch. Allow the joint to set before disturbing in any way.

22. Irrespective of the attitude of the switch when installed, as much of the grommet as possible is to be turned down. The grommet

and cables should be securely fixed in position, by lashing or cleating in accordance with the general installation methods in use on the aircraft. If the cable is encased in a tube, either a short length of cable must be exposed (fig. 6c), or the tube must be pierced at its lowest point (fig. 6d) to permit the egress of accumulated moisture.

23. A view of various types of cable grommets used with the 1831Y micro-switch are shown in fig. 7, and a conversion chart from the earlier types to the later types are tabulated in Appendix 1. Fig. 7 and Appendix 1 should be read in conjunction with one another. Maximum overall dimensions of the various types of cable grommets are detailed in Leading Particulars and table 1.

RESTRICTED

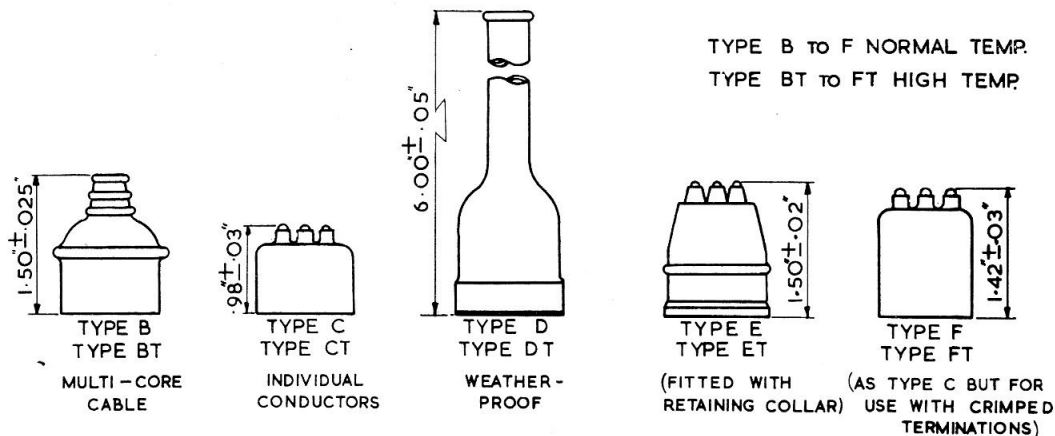

Fig. 7. View of various types of cable grommets

SERVICING

◀ 24. This series of microswitches should not be dismantled for further servicing at user units. Routine servicing is therefore restricted to a thorough examination for security of connections, mounting, deterioration of cables and any signs of corrosion. The unit should be tested for correct operation when connected to its relevant circuit. ▶

TESTING

Millivolt drop test

25. With the contacts carrying a current of 5 amperes, the millivolt drop taken at the terminals should not exceed 150 millivolts.

Insulation resistance test

26. Using a 250V d.c. insulation resistance tester, the insulation readings measured between all insulated parts of the switch and earth should not be less than 5 megohms (R.A.F.) and 0.5 megohms (R.N.).

TABLE 1
"Dowmic" switches, Mk. 101 to 104

| Type | Termination | Temperature range of switch |
|--------------------------------------|---------------------------------|-----------------------------|
| 1831Y, Mk. 101 | SBAC socket | -40 to +70 deg. C. |
| 1831Y, Mk. 102 | 6 B.A. terminal screws | -40 to +70 deg. C. |
| 1831Y, Mk. 103 | SBAC socket | -65 to +150 deg. C. |
| 1831Y, Mk. 104 | 6 B.A. terminal screws | -65 to +150 deg. C. |
| Maximum overall dimensions in inches | | |
| Height | | 2.81 |
| Width | | 1.17 |
| Length | | |
| | without cable entry grommet | 1.83 |
| | with grommet type B, or type BT | 3.36 |
| | with grommet type C, or type CT | 2.84 |
| | with grommet type D, or type DT | 7.52 |
| | with grommet type E, or type ET | 3.36 |
| | with grommet type F, or type FT | 3.28 |

RESTRICTED

Appendix 1

MICROSWITCH, TYPE C1831Y SERIES

CONVERSION TABLE

| Type 1831Y Mk. | Ref. No. 5CW/ | Type 1831Y Mk. | Ref. No. 5CW/ | Terminal connections | Cable Entry | Special feature |
|----------------|---------------|----------------|---------------|----------------------|---|--------------------------------|
| 1 | 4742 | 101C | 6976 | S.B.A.C. | Weatherproof grommet | |
| 2 | 4904 | 102C | 6977 | 6 B.A. screws | Weatherproof grommet | |
| 3 | | — | | | | |
| 4 | | — | | | | |
| 5 | | — | | | | |
| 6A | | 102A | 7828 | | | |
| 6B | | 102B | 8018 | 6 B.A. screws | Type 'B' grommet (single entry for multicore cable) | |
| 7 | | — | | | | |
| 8 | | — | | | | |
| 9 | 6322 | 101D | 6978 | S.B.A.C. | Special grommet | Sealed |
| 10 | 6798 | 102D | 7724 | 6 B.A. screws | Special grommet | Sealed |
| 11 | | — | | | | |
| 12 | 6372 | 103 | 6979 | S.B.A.C. | No grommet fitted | High temperature (150 deg. C.) |
| 13 | | — | | | | |
| 14 | | — | | | | |
| 15 | 6321 | 101C | 6976 | S.B.A.C. | Weatherproof grommet | |
| 16 | | 102F | 8808 | | Weatherproof grommet | Six entry long |
| 17 | | 102C | 6977 | | | |
| 18 | 7095 | 104CT | | | | |
| 19 | 6766 | 101D | 6978 | S.B.A.C. | Special grommet | Sealed |
| 20 | | — | | | | |
| 21 | | — | | | | |
| 22 | 7296 | 102F | 8808 | 6 B.A. screws | Weatherproof grommet for A-MP tags | |
| 23 | | 102D | 7724 | | | |
| 24 | | — | | | | |

RESTRICTED

This file was downloaded
from the RTFM Library.

Link: www.scottbouch.com/rtfm

Please see site for usage terms,
and more aircraft documents.

