

Chapter 33

SWITCH, MAGNETIC, TYPE 5Y (ROTAX D.6301)

LIST OF CONTENTS

	Para.		Para.
Introduction	1	Servicing	7
Description	2	Coil resistance test	8
Operation	4	Millivolt drop test	9
Installation	5	Insulation resistance tests	10

LIST OF ILLUSTRATIONS

	Fig.		Fig.
Magnetic switch, Type 5Y	1	Diagram of internal connections	2

LEADING PARTICULARS

Switch, magnetic, Type 5Y	Stores Ref. 5CW/5305
Voltage	
Main contacts	208-V., 400 c.p.s. 3-phase a.c.
Coil	28-V. d.c.
Current rating (line)	10 amperes
Rating	Continuous
Coil resistance at 20 deg. C	93 ohm. \pm 7½ per cent
Minimum pull-in voltage	16-V. d.c.
Operational ceiling	50,000 ft.
Operational temperature range	— 65 deg. C. to + 50 deg. C.
Length	3.375 in.
Width	1.937
Height	2.437
Weight	11 oz.

Introduction

1. The Type 5Y magnetic switch is a three-phase contactor designed for use in a 208-V. 400 c.p.s. a.c. circuit and having a current rating of 10 amperes per line. The contacts are operated by a 28-V. d.c. solenoid coil which is continuously rated.

DESCRIPTION

2. The contactor is contained within a rectangular moulded housing, having on each of two opposite sides three main terminals set in projecting separately shielded entries. Beneath one of the sets of three entries are two entries for the coil terminals. The housing is screwed to a metal base plate and four clearance mounting holes pass through both the base plate and flanges on the moulded housing.

3. Two solenoid coils in series, having soft iron cores and a common yoke are mounted on the metal base plate within the housing. Above the coils, an armature is hinged to a bracket which is screwed to the sides of the housing. The armature carries a moulded contact carrier which has three moving contacts fitted to it, each contact being commoned by a flexible connector to one of the three main terminals (A, B and C) remote from the coil terminals. Each moving contact has a mating fixed contact commoned to a corresponding terminal of the remaining set of three main terminals (L1, L2 and L3). The moving contacts are normally held above their mating contacts (i.e., in the "open" position) by torsion return springs on the armature hinge pin. The contacts are enclosed by a screw retained moulded cover.

(A.L.95, Feb. 57)

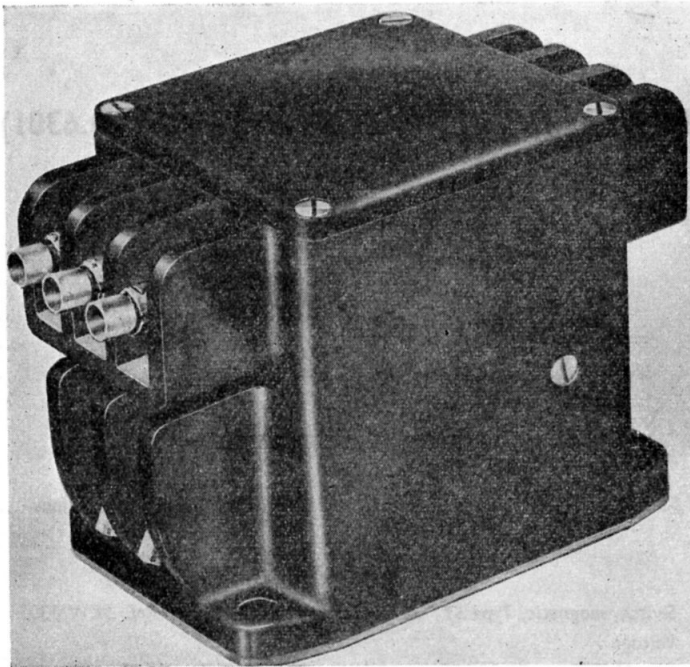

Fig. 1. Magnetic switch, Type 5Y

Operation

4. When the coil is energized, the armature is drawn down so that the three pairs of contacts mate simultaneously. When the coil is de-energized, the torsion spring returns the armature and contacts to normal.

INSTALLATION

5. Four .189 in. diameter clearance holes are provided at the base for mounting. Their fixing centres form a rectangle 2.500 in. by 1.375 in.

6. All terminals are standard 19 ampere S.B.A.C. connectors.

SERVICING

7. Remove the contact cover and examine the contacts for signs of excessive burning and pitting. Ensure also that the switch has not sustained any damage, that it is secure on its mounting and that the external connections are in good condition.

Coil resistance test

8. The resistance of the two coils in series, measured between terminals CT and ET, and corrected to 20 deg. C. ambient temperature, should be between 86 and 100 ohm.

Millivolt drop test

9. Energize the coil to close the contacts and then allow a current of 10 amperes d.c. to flow between each pair of main terminals in turn. The potential drop across each pair of mating contacts should not exceed 10 millivolt, whilst the potential drop across corresponding pairs of terminals should not exceed 50 millivolt.

Insulation resistance tests

10. Measure the insulation resistance between the following points using a 500-V. insulation resistance tester. A reading of at least 50,000 ohm. should be obtained in each test.

- (1) Contacts closed
 - (a) Terminal A and terminals B and C
 - (b) Terminal B and terminal C
 - (c) Terminal CT and terminals A, B and C
 - (d) Frame and terminals A, B and C
- (2) Contacts open
 - (a) Terminal A and terminal L1
 - (b) Terminal B and terminal L2
 - (c) Terminal C and terminal L3

RESTRICTED

II. Measure the insulation resistance between frame and terminal CT, using a 250-V. insulation resistance tester. A reading of at least 50,000 ohm. should be obtained.

Note . . .

The values of insulation resistance given in paras. 10 and 11 apply to switches being tested under normal workshop conditions. Due allowance should be made for the climatic conditions of the locality and those of the aircraft servicing area or dispersal point where the tests are being applied. In particularly damp climates, readings may be low enough to give apparently sufficient reason for rejection and, in these instances, discretion should be exercised.

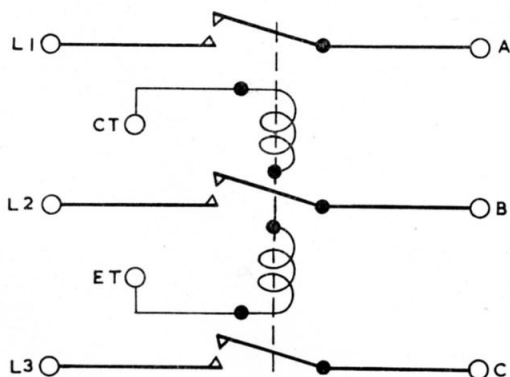

Fig. 2. Diagram of internal connections

This file was downloaded
from the RTFM Library.

Link: www.scottbouch.com/rtfm

Please see site for usage terms,
and more aircraft documents.

