

Chapter 15

TEMPERATURE SELECTORS, TYPE FHK

LIST OF CONTENTS

| | <i>Para.</i> | | <i>Para.</i> |
|---------------------------|--------------|------------------------------------|--------------|
| <i>Introduction</i> | 1 | Servicing | 10 |
| Description | 3 | <i>Insulation resistance</i> | 11 |
| Operation | 8 | <i>Bonding resistance</i> | 12 |
| | | <i>Electrical resistance</i> | 13 |

LIST OF ILLUSTRATIONS

| | <i>Fig.</i> | | <i>Fig.</i> |
|--|-------------|---|-------------|
| <i>Typical temperature selector, Type FHK</i> | 1 | <i>Sectional view of typical temperature selector, Type FHK</i> | 3 |
| <i>Exploded view of typical temperature selector, Type FHK</i> | 2 | <i>Typical temperature selector, Type FHK, circuit diagram</i> | 4 |

LIST OF APPENDICES

| | <i>App.</i> | | <i>App.</i> |
|---|-------------|---|-------------|
| <i>Temperature selectors, Type FHK (automatic control)</i> | 1 | <i>Temperature selectors, Type FHK (de-icing)</i> | 3 |
| <i>Temperature selectors, Type FHK (automatic and manual control)</i> | 2 | | |

Introduction

1. Temperature selectors, Type FHK, are essentially variable resistances. They are usually connected, in temperature control systems as part of the amplifier bridge network, and in de-icing systems in the d.c. supply to the cyclic switch.

2. There is a variety of temperature selectors, the general principle of operation being the same for all. Essential differences are detailed in the appendices.

DESCRIPTION

3. A typical temperature selector, Type FHK, contains a toroidally wire-wound potentiometer mounted within a Bakelite drum. A spring-loaded contact brush attached to a central spindle, sweeps over the windings when the spindle is rotated. A brass snap cap encloses the windings and brush.

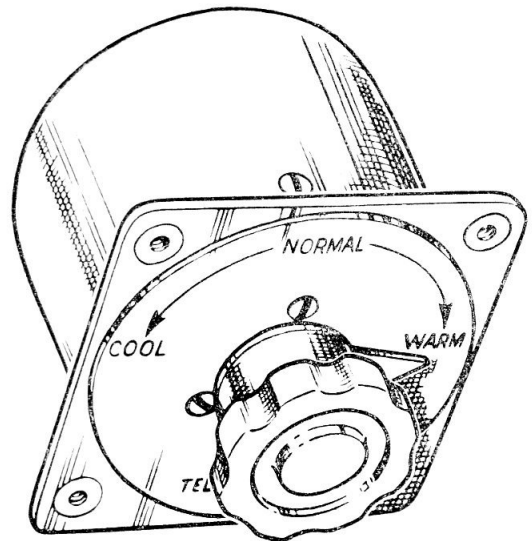

Fig. 1. Typical temperature selector, Type FHK.

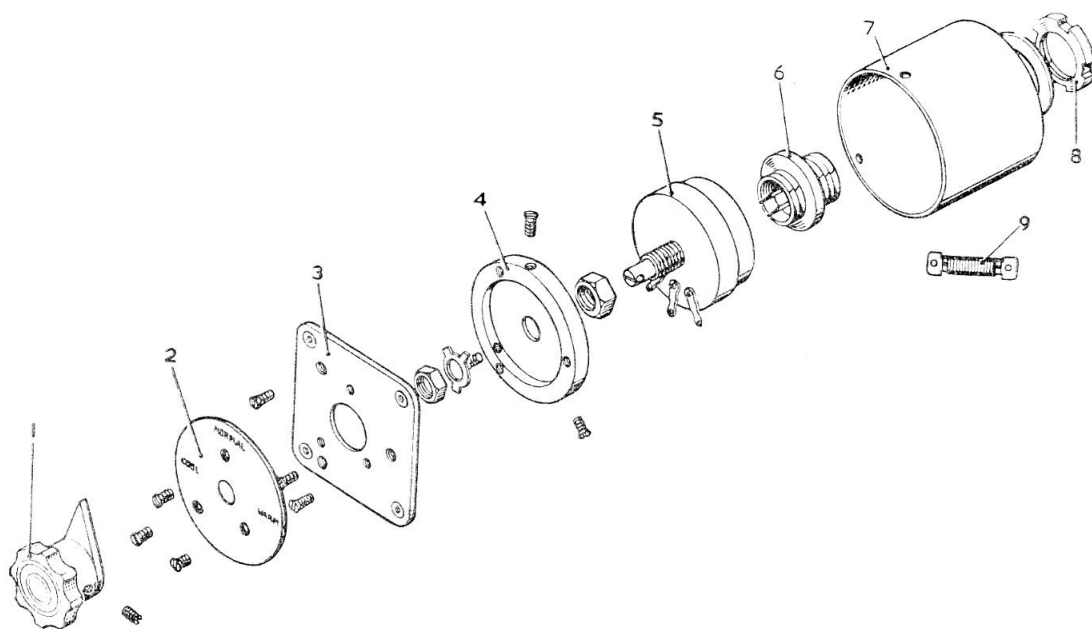

Fig. 2. Exploded view of typical temperature selector, Type FHK.

- 1 KNOB AND POINTER
- 2 DIAL
- 3 MOUNTING PLATE
- 4 MOUNTING DISC
- 5 POTENTIOMETER

- 6 2-POLE PLUG
- 7 COVER DRUM
- 8 RING NUT
- 9 FIXED RESISTOR

4. In addition to the potentiometer a fixed resistor is fitted in some selectors. This resistor is connected in series with the potentiometer, and may be mounted externally to the potentiometer or situated within its case.

5. The potentiometer (5, *fig. 2 and 3*), is secured to a mounting disc (4) of aluminium alloy, by means of two panel mounting nuts and a tab washer. A square mounting plate (3) of aluminium alloy, is secured to the face of the mounting disc (4) by three countersunk head screws. A graduated anodised aluminium dial (2), is secured to the face of the mounting plate also by three countersunk head screws. The four hank rivet bushes (screwed rivet bushes), one at each corner of the mounting plate, are for panel mounting the selector. The spindle projects through the centre of the dial, and a Bakelite knob and pointer (1) is secured to the end of the spindle by a grub screw.

6. A brass cover drum (7), upon which is mounted a 2-pole Mk. 4 plug (6), encloses the potentiometer and mounting disc, being secured to the latter by three countersunk head screws. The potentiometer, brush, and (where fitted) fixed resistor connections, are taken within the cover drum to the plug. Where a fixed resistor is fitted and is external to the potentiometer (9), it is secured by two bolts and two tubular mounting pillars to the inside of the cover drum.

7. The circuit diagram of a typical selector is shown in *fig. 4*.

OPERATION

8. When the selector is fitted in the amplifier bridge network of the temperature control system, its resistive value and the graduations on the dial are such that rotation of the knob to a new value causes the amplifier

RESTRICTED

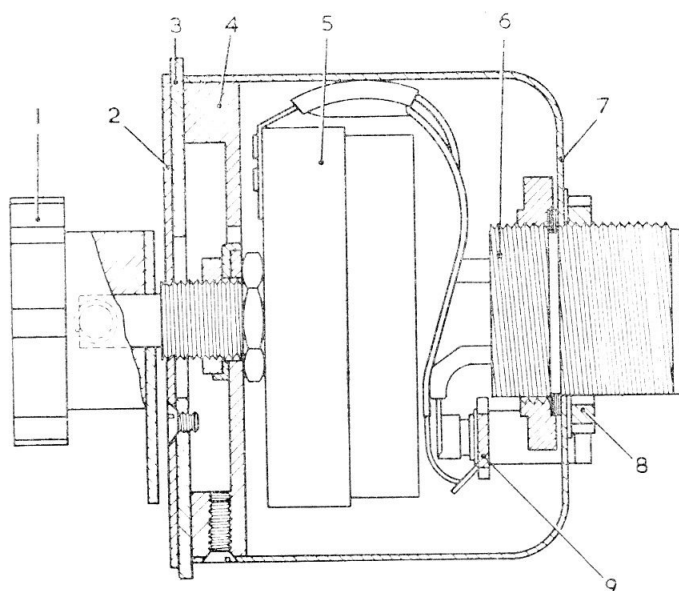

Fig. 3. Sectional view of typical temperature selector, Type FHK.

- 1 KNOB AND POINTER
- 2 DIAL
- 3 MOUNTING PLATE
- 4 MOUNTING DISC
- 5 POTENTIOMETER

- 6 2-POLE PLUG
- 7 COVER DRUM
- 8 RING NUT
- 9 FIXED RESISTOR

bridge network to lose equilibrium, and pass a signal to the heat control actuators. As a result of the actuators movement, the cabin temperature changes towards the temperature selected until the temperature detected by the cabin sensing element is that required by the selector. At this point a new balance of the bridge network is struck, and the control system is passive until the bridge is again disturbed.

9. The temperature selector, when used in a de-icing circuit, controls the input voltage to a cyclic de-icing switch governing the rate of switching.

SERVICING

10. Reference should first be made to the Appendix applicable to the type of selector being serviced. The selector should be

examined generally for damage, security and excessive wear.

Insulation resistance

11. The insulation resistance between all the poles on the plug, or terminals on the terminal block, and the mounting plate should be not less than 5 megohms at 250V. d.c.; the test being carried out at approximately 20°C.

Bonding resistance

12. The bonding resistance between the connection plug shroud and the cover drum (outer case and front plate on units fitted with a terminal block), must not exceed 0.025 ohm.

Electrical resistance

13. When the selector knob is in the positions stated in the appropriate resistance values table in the appendices, the electrical

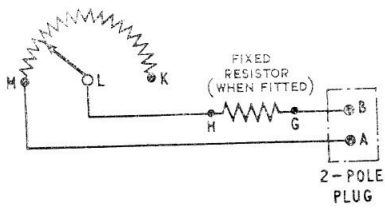

Fig. 4. Typical temperature selector,
Type FHK, circuit diagram.

resistance between poles A and B on the plug, or terminals B and C on the terminal block, must be within the limits specified; the test being carried out at approximately 20°C. The changes in resistance should occur steadily.

Appendix 1

TEMPERATURE SELECTORS, TYPE FHK (AUTOMATIC CONTROL)

General

1. The temperature selectors in this group are used in aircraft temperature control systems, and termed "automatic control" as selection of a desired temperature automatically sets in motion a cycle of operations to achieve the selected value.

2. These selectors are generally similar in construction and operation to the typical unit described in the main chapter. Each selector weighs approximately $7\frac{1}{2}$ oz., and its overall dimensions are $2\frac{1}{2}$ in. \times $2\frac{1}{2}$ in. \times $3\frac{1}{4}$ in. long with slight variations according to type.

TYPES

3. The essential differences between the various selectors in the "automatic control" group, are detailed under the particular type number.

Type FHK/A/4. Ref. No. 5CZ/5389

This selector has no fixed resistor, and the internal connections are from the plug pole A to potentiometer terminal L, and from potentiometer terminal K to the plug pole B. It has dial markings of 60 to 110 deg. F. by 5 deg. intervals.

| Resistance values | |
|------------------------------|----------------------|
| Dial indication (deg. F.) | Resistance (ohms) |
| 60 | 59.0 ± 2 |
| 65 | 53.8 ± 2 |
| 70 | 48.2 ± 2 |
| 75 | 42.4 ± 2 |
| 80 | 37.1 ± 2 |
| 85 | 31.6 ± 2 |
| 90 | 25.8 ± 2 |
| 95 | 20.1 ± 2 |
| 100 | 14.2 ± 2 |
| 105 | 8.5 ± 2 |
| 110 | 3.9 ± 2 |

Type FHK/A/7. Ref. No. 5CZ/4900

A resistor, external to the potentiometer, of value 370 ± 1 ohms is fitted in this selector. The internal connections are as shown in fig. 4 of the main chapter. The dial markings are COOL, NORMAL and WARM.

Resistance values

| Dial indication | Resistance (ohms) |
|-----------------|----------------------|
| Cool | 370 ± 5 |
| Normal | 470 ± 10 |
| Warm | 570 ± 15 |

Type FHK/A/11. Ref. No. 5CZ/5088

A fixed resistor is incorporated in the potentiometer of this unit, and the internal connections are from the plug pole A to the potentiometer terminal M, and from the potentiometer terminal L to the plug pole B. The dial markings are COOL, NORMAL and WARM.

Resistance values

| Dial indication | Resistance (ohms) |
|-----------------|----------------------|
| Cool | 300 ± 15 |
| Normal | 400 ± 20 |
| Warm | 500 ± 25 |

Type FHK/A/14. Ref. No. 5CZ/5257.

This selector has a fixed resistor incorporated in the potentiometer, and the internal connections are from the plug pole A to the potentiometer terminal M, and from the potentiometer terminal L to the plug pole B. The dial is graduated from 1 to 10.

Resistance values

| Dial indication | Resistance (ohms) |
|-----------------|----------------------|
| 1st line | $420 \pm 5\%$ |
| 2nd line | $425 \pm 5\%$ |
| 3rd line | $440 \pm 1\%$ |
| 4th line | $455 \pm 1\%$ |
| 5th line | $470 \pm 1\%$ |
| 6th line | $485 \pm 1\%$ |
| 7th line | $500 \pm 1\%$ |
| 8th line | $515 \pm 1\%$ |
| 9th line | $530 \pm 1\%$ |
| 10th line | $545 \pm 1\%$ |

Type FHK/A/15. Ref. No. 5CZ/

A resistor, external to the potentiometer and of value 421 ± 1 ohms, is fitted in this selector; the internal connections are as shown in fig. 4 of the main chapter. The dial is marked COOL, NORMAL and WARM, and in addition has 10 lines.

| Resistance values | |
|-------------------|-------------------|
| Dial indication | Resistance (ohms) |
| 1st line | 421 ± 5 |
| 2nd line | 448 ± 5 |
| 3rd line | 487 ± 5 |
| 4th line | 529 ± 6 |
| 5th line | 571 ± 6 |
| 6th line | 615 ± 7 |
| 7th line | 660 ± 7 |
| 8th line | 707 ± 8 |
| 9th line | 756 ± 8 |
| 10th line | 803 ± 8 |

Type FHK/A/17. Ref. No. 5CZ/5238

A fixed resistor is incorporated in the potentiometer of this unit; the internal connections are from the plug pole A to the potentiometer terminal M, and from potentiometer terminal L to the plug pole B. The dial graduations are -30 to $+25$ deg. C. by 5 deg. intervals.

| Resistance values | |
|---------------------------|-------------------|
| Dial indication (deg. C.) | Resistance (ohms) |
| -30 | $300 \pm 5\%$ |
| -25 | $320 \pm 5\%$ |
| -20 | $340 \pm 1\%$ |
| -15 | $360 \pm 1\%$ |
| -10 | $380 \pm 1\%$ |
| -5 | $400 \pm 1\%$ |
| 0 | $420 \pm 1\%$ |
| 5 | $440 \pm 1\%$ |
| 10 | $460 \pm 1\%$ |
| 15 | $480 \pm 1\%$ |
| 20 | $500 \pm 1\%$ |
| 25 | $520 \pm 1\%$ |

Type FHK/A/20. Ref. No. 5CZ/5081

This selector has a fixed resistor incorporated in the potentiometer, and the internal connections are from plug pole A to potentiometer terminal M, and from potentiometer

terminal L to plug pole B. The dial graduations are from 1 to 10.

| Resistance values | |
|-------------------|-------------------|
| Dial indication | Resistance (ohms) |
| 1st line | $420 \pm 5\%$ |
| 2nd line | $425 \pm 5\%$ |
| 3rd line | $440 \pm 1\%$ |
| 4th line | $455 \pm 1\%$ |
| 5th line | $470 \pm 1\%$ |
| 6th line | $485 \pm 1\%$ |
| 7th line | $500 \pm 1\%$ |
| 8th line | $515 \pm 1\%$ |
| 9th line | $530 \pm 1\%$ |
| 10th line | $545 \pm 1\%$ |

Type FHK/A/26. Ref. No. 5CZ/5297

A 370 ± 1 ohms resistor is fitted externally to the potentiometer in this selector; the internal connections are as shown in fig. 4 in the main chapter. Dial markings are COOL, NORMAL and WARM.

| Resistance values | |
|-------------------|-------------------|
| Dial indication | Resistance (ohms) |
| Cool | 370 ± 5 |
| Normal | 470 ± 10 |
| Warm | 570 ± 15 |

Type FHK/A/32. Ref. No. 5CZ/5863

A fixed resistor, of value 291 ± 1 ohms, is mounted externally to the potentiometer in this selector; the internal connections are as shown in fig. 4 of the main chapter. The dial markings are from -25 to $+95$ deg. C. by increments of 10 deg. C.

| Resistance values | |
|-------------------|-------------------|
| Dial indication | Resistance (ohms) |
| 1st line | 324 ± 4 |
| 13th line | 795 min. |

Type FHK/A/36. Ref. No. 5CZ/5961

This selector has a fixed resistor, $100 \pm \frac{1}{2}$ ohms, mounted externally to the potentiometer; internal connections are as shown in fig. 4 of the main chapter. The dial markings

on this selector are COOL and OUT, with ten intermediate lines.

| Resistance values | |
|-------------------|-------------------|
| Dial indication | Resistance (ohms) |
| 1st line (COOL) | 100 \pm 5 |
| last line (OUT) | 5,100 \pm 300 |

Type FHK/A/37. Ref. No. 5CZ/6017

This unit has no fixed resistor. The dial

markings are 65 to 85 deg. F. by increments of 5 deg.

| Resistance values | |
|---------------------------|-------------------|
| Dial indication (deg. F.) | Resistance (ohms) |
| 65 | 53.8 \pm 2 |
| 70 | 48.2 \pm 2 |
| 75 | 42.4 \pm 2 |
| 80 | 37.1 \pm 2 |

Appendix 2

TEMPERATURE SELECTORS, TYPE FHK (AUTOMATIC AND MANUAL CONTROL)

General

1. The temperature selectors in this group are used in aircraft temperature control systems and termed "automatic and manual control" as, in addition to being able to select a desired temperature which is automatically achieved by the operation of the control system, the control system may be by-passed; the valve actuator being operated directly (or via relays) from the selector.

DESCRIPTION

2. Temperature selectors in this group are similar in construction to the typical selector described in the main chapter, except that they have in addition contact rings and contacts (fig. 1), and a 6-pole in lieu of a 2-pole Mk. 4 plug (fig. 2). Each selector weighs approximately $9\frac{1}{2}$ oz., and the overall dimensions are $2\frac{3}{8}$ in. \times $2\frac{3}{8}$ in. \times 4 in. long.

OPERATION

3. The selectors in this group operate in a similar manner to the typical selector described in the main chapter, but included

in these items is a switch unit which enables the system to be transferred from automatic to manual operation.

4. A 28V. d.c. positive supply is fed to the inner contact ring on the switch plate, and for 270 deg. rotation of the potentiometer shaft, i.e. whilst the knob registers AUTO, it is connected to the outer ring through the wiper arms which are carried by a sleeve keyed to the shaft. From the outer ring it is conducted via the plug, to the d.c. sections of the system amplifier.

5. When the knob is rotated off the AUTO section, the wiper arm leaves the outer ring thus interrupting the d.c. positive supply to the amplifier. Further movement of the knob will bring the wiper arm on to one of two silver contacts on the switch plate. These contacts are connected one to the "open" and the other to the "close" side of the valve actuator, either directly or through a relay. The d.c. positive supply from the inner ring is thus conducted to the actuator to produce a movement resulting in a re-positioning of the valve.

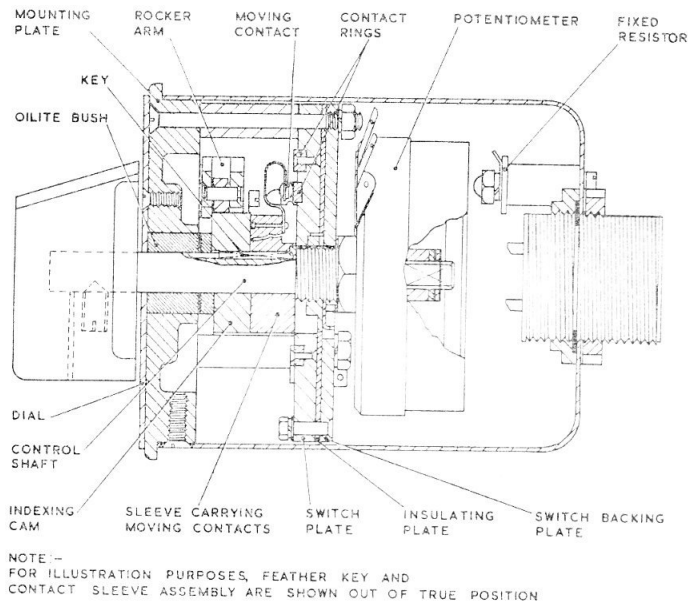

Fig. 1. Sectional view of temperature selector, Type FHK, automatic and manual control

RESTRICTED

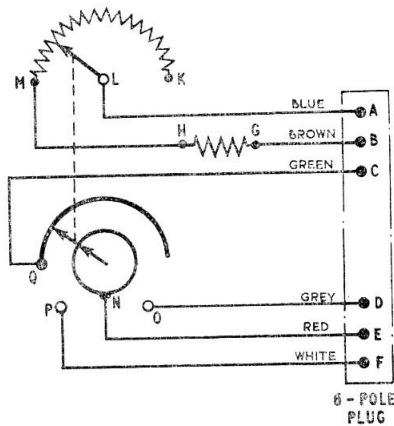

Fig. 2. Temperature selector, Type FHK, automatic & manual, circuit diagram

6. Continuity between the wiper arm and the two silver contacts is maintained only for as long as the knob is held manually in position. As soon as the knob is released, the switch will move into a neutral position between the contacts. This is brought about by a cam and spring loaded rocker arm.

7. Whilst the selector is operating on AUTO, a roller on the rocker arm bears on the circular profile of the cam. As the selector is moved from the AUTO section, the cam rides over a sharp lobe on the cam to rest in a small hollow. At this point contact is being made with one of the silver contacts, and springs attached to the rocker arm are under tension exerting a torque on the cam. Release of the knob allows this torque to rotate the cam, the inner edge of the hollow being insufficient to lock the roller which falls into a register co-incident with the neutral position. The sharp lobe of the cam precludes any possibility of the selector inadvertently reverting to the AUTO position by preventing the roller moving in that direction.

SERVICING

8. In addition to the servicing instructions contained in the main chapter, the contact and insulation resistance between certain points must be checked.

Contact resistance

9. The contact resistance measured between the following points should not exceed 0.06 ohm.

- (a) E and D when the selector knob is manually operated to WARM.
- (b) Pins E and F when the selector knob is manually operated to COOL.
- (c) Pins E and C when the knob is in any AUTO position.

Insulation resistance

10. The insulation resistance between the following points must not be less than 5 megohms at 250V. d.c.; the test being carried out at approximately 20 deg. C.

- (a) Pin A and pins B, C, D, E and F in turn with the selector set (but not held) to MANUAL.
- (b) Pin A and pins C, D, E and F in turn with the selector set to AUTO.
- (c) Any two of pins C, D, E or F with the selector set (but not held) in the MANUAL position.

TYPE

11. The essential differences between the various selectors in the "automatic and manual control" group are detailed under their particular type number.

Type FHK/A/22. Ref. No. 5CZ/5404.

A 370 ± 1 ohms fixed resistor is fitted externally to the potentiometer in this unit. The dial markings are MANUAL FIXED, COOL, AUTO and WARM. The internal connections are as shown in fig. 2.

Resistance values

| Selector knob position | Resistance (ohms) |
|-------------------------|-------------------|
| Fully counter-clockwise | 370 ± 5 |
| Fully clockwise | 570 ± 15 |

Type FHK/A/38. Ref. No. 5CZ/

A 370 ± 1 ohms fixed resistor is fitted externally to the potentiometer in this unit. The dial markings are MANUAL FIXED, COOL, AUTO and WARM; in addition the AUTO section is sub-divided between COOL and WARM from 5 to 55 respectively, by increments of 5. The numbers on the dial refer to degrees C. Internal connections are as shown in fig. 2.

Resistance values

| Selector knob position | Resistance (ohms) |
|-------------------------|-------------------|
| Fully counter-clockwise | 370 ± 5 |
| Fully clockwise | 570 ± 15 |

Appendix 3

TEMPERATURE SELECTORS, TYPE FHK (DE-ICING)

General

1. The temperature selectors in this category are designed to control the 28V. d.c. supply to a cyclic de-icing switch, thereby regulating its motor speed and hence its rate of switching.

DESCRIPTION

2. Temperature selectors in this group differ from the typical unit described in the main chapter, in that they have a triple ganged potentiometer (*fig. 1*), instead of a single unit, and are connected electrically as a potential divider and not as a variable resistance. In lieu of a miniature Mk. 4 a 3-way terminal block is fitted. A locking clutch is interposed between the control knob and the central spindle.

3. The weight of each selector in this group is approximately $10\frac{1}{2}$ oz., and the overall dimensions are $2\frac{3}{8}$ in. \times $2\frac{3}{8}$ in. \times $5\frac{7}{16}$ in. long.

OPERATION

4. By reference to *fig. 2*, it will be seen that the ganged potentiometer is used to vary the output voltage of a 28V. d.c. input supply. When connected in a cyclic de-icing switch circuit, it regulates the input voltage and hence the speed of a motor, which sets the rate of sequential switching of an a.c. supply to the aircraft aerofoil heater mats.

5. The dial is engraved to correspond with the prevailing external temperature, so that the central knob can be set to give an output voltage which will produce a switching rate sufficient to meet icing conditions. Re-setting is achieved by pressing on the knob against the loading of a spring to disengage the locking clutch plates, and allowing the spindle to rotate. Release of the knob results in a re-engagement of the clutch to lock the spindle in its new position.

6. The three wire wound, rotary potentiometers, mechanically ganged and electrically

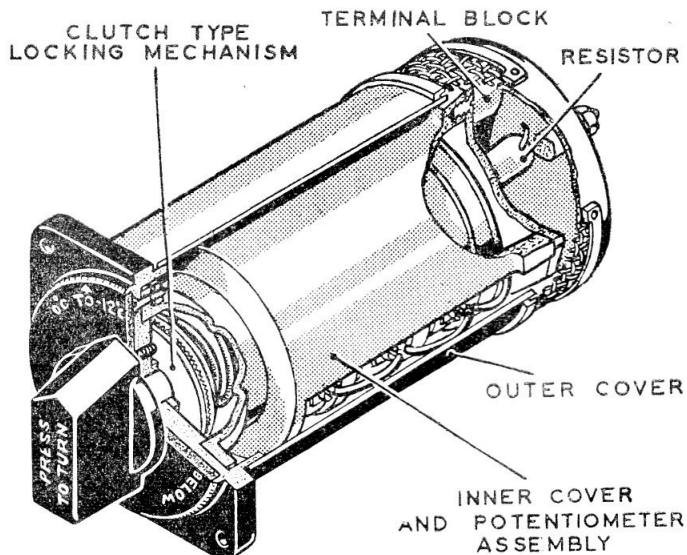

Fig. 1. Temperature selector, Type FHK/A/42

RESTRICTED

paralleled, are used to give a high current carrying capacity without excessive bulk and weight.

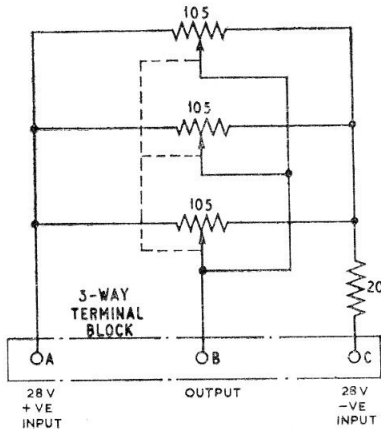

Fig. 2. Temperature selector, Type FHK/A/42 circuit diagram

SERVICING

7. In addition to the servicing instructions contained in the main chapter, the resistance value between terminals A and C must be checked to ensure that it comes within the value specified under the appropriate type heading.

TYPE

8. The essential differences between the various selectors in the "de-icing" group are detailed under their particular type number.

Type FHK/A/30. Ref. No. 5CZ/5571

Two $20 \pm 5\%$ ohms resistors are fitted externally to the potentiometer in this unit. The dial markings are $0^\circ\text{C. TO } -12^\circ\text{C.}$,

$-12^\circ\text{C. TO } -25^\circ\text{C.}$, and $-25^\circ\text{C. AND BELOW}$. Internal connections are as shown in fig. 2 except that the additional 20 ohm resistor is fitted between terminal A and the potentiometer connection.

Resistance values

| Dial indication | Resistance (ohms) |
|---|-------------------|
| Knob fully counter-clockwise | 55 ± 5.5 |
| $0^\circ\text{C. TO } -12^\circ\text{C.}$ | 35 ± 3.5 |
| $-12^\circ\text{C. TO } -25^\circ\text{C.}$ | 28 ± 2.8 |
| BELOW -25°C. | 22.5 ± 2.25 |
| Resistance between terminals A and C | |
| | 75 ± 7.5 |

Type FHK/A/42. Ref. No. 5CZ/

This selector has a $20 \pm 5\%$ ohms resistor fitted externally to the potentiometer. The dial markings are $0^\circ\text{C. TO } -12^\circ\text{C.}$, $-12^\circ\text{C. TO } -25^\circ\text{C.}$ and $-25^\circ\text{C. AND BELOW}$. Internal connections are as shown in fig. 2.

Resistance values

| Dial indication | Resistance (ohms) |
|---|-------------------|
| Knob fully counter-clockwise | 55 ± 1 |
| $0^\circ\text{C. TO } -12^\circ\text{C.}$ | 43.5 ± 0.5 |
| $-12^\circ\text{C. TO } -25^\circ\text{C.}$ | 32.5 ± 0.5 |
| BELOW -25°C. | 26 ± 0.5 |
| Knob fully clockwise | 22.5 ± 1 |
| Resistance between terminals A and C | |
| | 55 ± 1 |

The total angular displacement of the knob must be $236 \text{ deg. } \pm 3 \text{ deg.}$

This file was downloaded
from the RTFM Library.

Link: www.scottbouch.com/rtfm

Please see site for usage terms,
and more aircraft documents.

