

Chapter 22

FIRE DETECTION RELAY UNIT, TYPE D.1740

(Completely revised)

LIST OF CONTENTS

	<i>Para.</i>		<i>Para.</i>
<i>Introduction</i>	1	Operation	10
Description	3	<i>Test condition</i>	13
<i>Relay unit</i>	5	Servicing	15
<i>Circuit</i>	8	<i>Testing</i>	16

LIST OF ILLUSTRATIONS

	<i>Fig.</i>		<i>Fig.</i>
<i>Relay unit and mounting base</i>	1	<i>Circuit diagram</i>	3
<i>Relay unit separated from base</i>	2		

LIST OF APPENDICES

	<i>App.</i>		<i>App.</i>
<i>Standard Serviceability Test for Relay unit Type D1740 (R.N.)</i>	A	<i>Standard Serviceability Test for Relay unit Type D1740 (R.A.F.)</i>	B

LEADING PARTICULARS

Relay unit, Type D1740	Ref. No. 5CZ/5917
<i>Warning relay operating current</i> 13-17mA
<i>Warning relay release current</i> 6-10mA
<i>Overall dimensions</i>	2.75 in. × 2.75 in. × 2 in.
<i>Weight</i>985 lb.
<i>Base unit Type D2240</i>	<i>Ref. No. 5CZ/5918</i>
<i>Base unit Type D2497</i>	<i>Ref. No. 5CZ/</i>

RESTRICTED

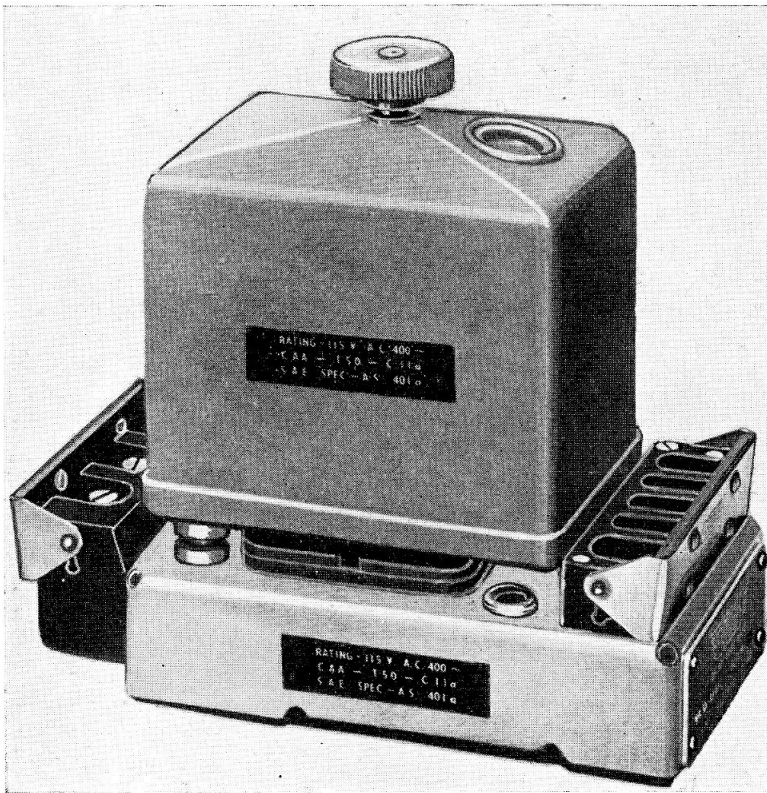

Fig. 1. Relay unit and mounting base

Introduction

1. The Graviner Type D1740 relay unit is a single-way unit used with a Graviner Firewire sensing element system to detect and indicate fire or overheat conditions in the monitored fire zone. The relay unit is used in conjunction with a mounting base, either Type D2240 or Type D2497, details of which are given in Chapter 21 of this Section, the mounting base described and illustrated in this chapter is the Type D2240.

2. This chapter deals with the relay unit only, details of the complete fire warning system are given in A.P.957C, Vol. 1, Part 1, Sect. 3, and in A.P.4343, Vol. 1, Sect. 22. Details of the sensing element system and accessories are given in Chap. 2 of this Section. Information on any particular system will be found in the relevant Aircraft Handbook.

DESCRIPTION

3. Two items comprise the complete control unit, the relay unit Type D1740 and either the base unit Type D2240 or the base unit

Type D2497. The base unit is permanently attached to the aircraft structure by three bolts and carries two terminal blocks to provide connections with the other components in the warning system. The relay unit is secured to the mounting base by a knurled-headed 2 B.A. captive bolt which passes through the centre of the unit and engages with a floating anchor nut in the base.

4. Electrical connection between the mounting base and the relay unit is made by spring loaded plungers on the mounting base which make contact with contact buttons situated on the lower face of the relay unit. This arrangement enables the relay unit to be removed from the aircraft, without disturbing the aircraft wiring, by releasing the knurled-headed securing bolt.

Relay unit

5. The unit consists of the following components, two miniature S.T.C. 4184JD relays, a full-wave bridge rectifier and a transformer. They are enclosed within a thin brass casing, the cover plate of which is flanged and

RESTRICTED

soldered to the main casing. An insulated contact plate, bearing eight contact buttons connected to the various components of the unit, is mounted on the cover plate.

6. The components are encapsulated within the casing by the introduction of a resin compound via a filling hole at the top of the casing. This hole is sealed by a plug which is spun into position and then soldered.

7. The 2 B.A. securing bolt runs through a tube in the centre of the unit and is retained by a circlip. Three spigots which mate with three sockets in the base unit serve to locate the relay unit in its correct position in relation to the mounting base.

coil of the warning relay is connected in series with the transformer secondary winding the bridge rectifier and the sensing element system via the test relay changeover contacts.

9. The coil of the test relay, R1/1 is connected to positive via the external test switch and to earth or negative via the sensing element outer capillary. The changeover contacts of the test relay are connected in series with the centre electrode in the normal position and when operated connect the centre electrode directly across the bridge rectifier-transformer secondary circuit.

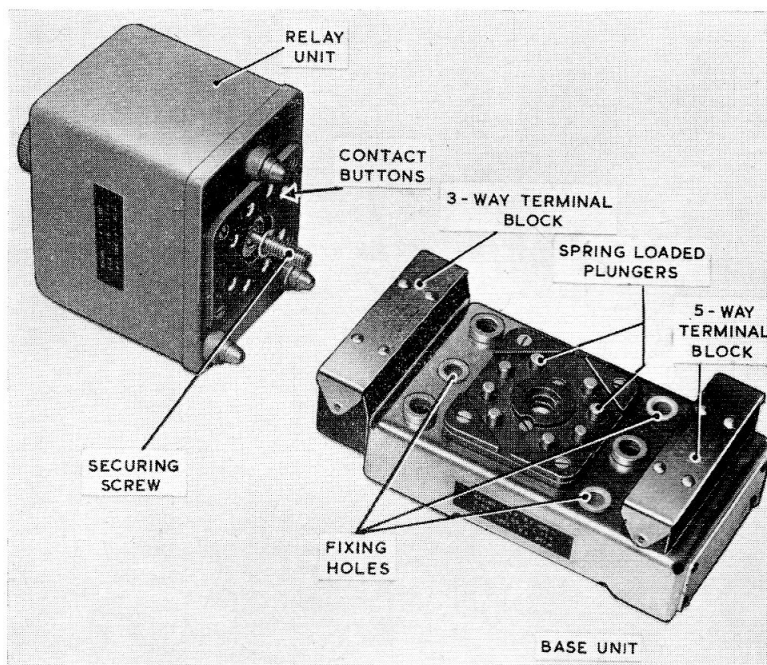

Fig. 2. Relay unit separated from base

Circuit

8. The circuit diagram for the relay unit is shown in fig. 3 together with a typical detection and warning system. The 115V a.c. supply is connected across the primary winding of the transformer and the 24V d.c. supply, with the warning lamp in the negative line, is connected across the normally open contacts of the warning relay, R2/1. The

OPERATION

10. Under normal ambient conditions the resistance of the filling material in the sensing element is such that the current flow between the inner and outer electrodes due to the secondary output of the transformer is restricted to a value in the order of 1mA. Under these conditions, the rectified current which flows through the operating coil of the

RESTRICTED

warning relay R2/1 is insufficient to cause the relay to operate and initiate a warning.

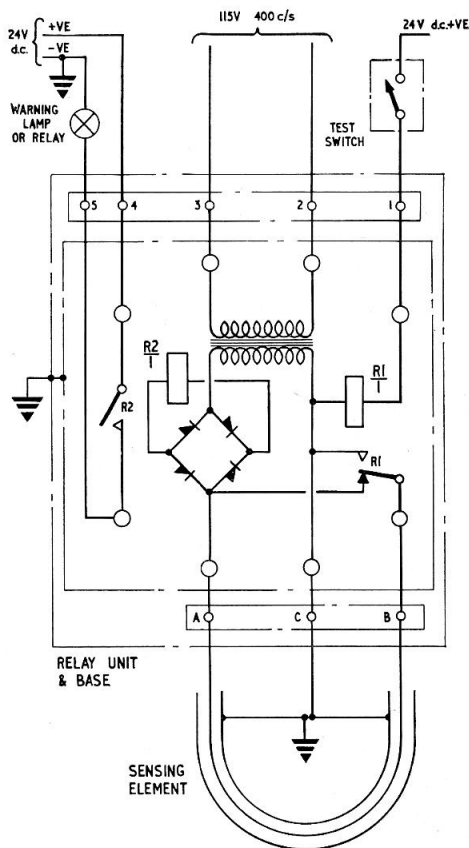

Fig. 3. Circuit diagram

11. An increase of temperature in the fire zone causes the resistance between the inner electrode to fall, due to the negative temperature coefficient of the filling material, consequently the rectified current through the relay coil will increase. When the temperature has risen to a value such that a current in the range of 13–17mA flows the relay will operate closing contacts R2 to complete the 24V d.c. warning circuit.

12. Should the fire zone temperature fall the resistance of the filling material will increase, causing the current through the operating coil of relay R2/1 to decrease. When this current falls to within the range

6–10mA the relay will be de-energized and the relay contacts open, breaking the warning circuit.

Test condition

13. Test relay R1/1 enables the continuity of the centre electrode in the sensing element and the satisfactory operation of the relay unit to be checked. When the external test switch is closed 24V d.c. is applied to the operating coil of the test relay which then operates. Contacts R1 change over to connect one end of the central electrode to the end of the secondary winding normally connected to the outer capillary.

14. This effectively connects the centre electrode across the secondary winding in series with the coil of the warning relay and the rectifier bridge. Provided continuity exists in this loop, sufficient current will flow to operate the relay and the warning lamp will be illuminated. A break in the central electrode will prevent the warning lamp from lighting, but it should be born in mind that a fault in the relay box, a faulty filament lamp or failure of the d.c. supply will also give this result.

Note . . .

A 330 ohm resistor is incorporated in the lead connecting the central electrode to the test relay in relay units bearing the Serial No. 457 and below.

SERVICING

15. Since the relay unit is completely sealed with a resin compound no dismantling is possible, servicing should be restricted to an examination to ensure that it is mechanically sound and undamaged. The base of the relay unit and the contact buttons should be examined for freedom from corrosion, oil contamination, pitting or burning. The mounting base should be serviced in accordance with the instructions given in Chap. 21 of this Section.

Testing

16. The relay box may be functionally tested using the procedure and test circuit given in the Standard Serviceability Tests, Appendices A and B.

Appendix A

STANDARD SERVICEABILITY TEST for FIRE DETECTION RELAY UNIT, TYPE D1740 (R.N.)

Introduction

1. The following tests may be applied to ascertain the serviceability of a relay box, or prior to its installation in an aircraft.

TEST EQUIPMENT

2. The following test equipment, or suitable equivalents, will be required:—

(1) A decade resistance box 0–11,110 ohms, Ref. No. 10S/16239.

(2) A single-pole changeover switch with centre-off position, Ref. No. 5CW/6431, and three single-pole ON/OFF tumbler switches, Ref. No. 5CW/6430.

(3) Two Type B warning lamps, Ref. No. 5CX/1553, fitted with 24V, 3.5 watt filament lamps.

(4) A 28V d.c. supply and a 115 volt, 400c/s a.c. supply.

(5) A 250V insulation resistance tester Ref. No. 0557/AP4047.

TEST PROCEDURE

Note . . .

Difference in test figures for relay boxes with a 330 ohm resistor fitted (Serial No. 1–457) are shown in brackets.

3. (1) Connect the relay box to a test circuit as shown in fig. 1 using a suitable mounting base.

(2) Set all switches to off and the decade resistance box to 1250 (900) ohms.

(3) Switch on the supplies and close switch C to position 1, ensure that the warning lamp remains extinguished.

(4) Set switch C to OFF and reduce the decade resistance to 250 (200) ohms.

(5) Close switch C to position 1 and ensure that the warning lamp is now illuminated.

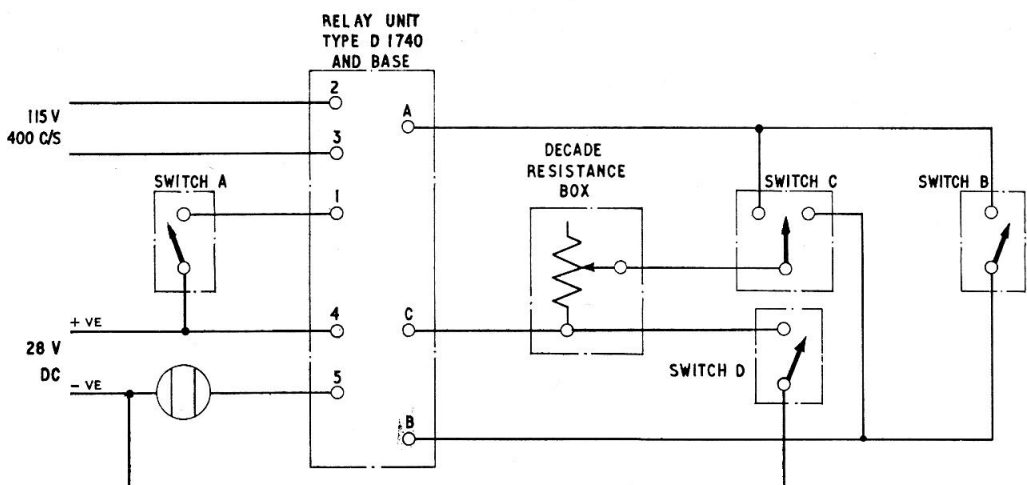

Fig. 1. Test circuit diagram

RESTRICTED

(6) Without breaking any circuits slowly increase the resistance of the decade resistor until the warning lamp is again extinguished.

(7) At this point the value of the decade resistance must be between 1300-5350 (1000-5000) ohms.

(8) Set switch C to OFF and repeat the procedure given in para. (2)-(7) with switch C in position 2.

(9) After completing the operating resistance checks above, set switch C to

OFF, switches A and B to ON, and switch D to ON and ensure that the warning lamp is illuminated.

(10) Set all switches to OFF, switch off the supplies and remove the relay unit from the test circuit mounting base.

Insulation resistance test

4. The insulation resistance of the relay unit may be measured using a 250V insulation resistance tester. The reading obtained when measuring between each contact button and the case should be not less than 20 megohms.

Appendix B

STANDARD SERVICEABILITY TEST

for

FIRE DETECTION RELAY UNIT, TYPE D1740 (R.A.F.)

Introduction

1. The following tests may be carried out to ascertain the serviceability of a relay unit, or prior to its installation in an aircraft.

TEST EQUIPMENT

2. The following test equipment, or suitable equivalents, will be required:—

- (1) Graviner Firewire test kit, Ref. No. 5G/3487.
- (2) An insulation resistance tester, Ref. No. 5G/152.
- (3) A 28V d.c. supply and a 115V, 400c/s a.c. supply.

TEST PROCEDURE

3. Set switches SA, SB and SC to position 1 and the resistance controls RV2 and RV1 fully counter-clockwise. Connect the No. 6 cable to plug B. Connect the free end of this cable to the 28V supply ensuring that the polarity is correct, positive to pin A and negative to pin B. Connect the No. 7 cable to plug A and the free end of this cable to the 115V, 400c/s a.c. supply. Remove the protective cover plate from Connector 2 and locate and secure the relay unit to be tested.



Note . . .

Switch SD is a scale change switch in the circuits of meters M1 and M2 and should not be operated during unit testing except where detailed. Operation of the switch gives readings on the 0-5mA scale of meter M1 and on the 0-40mA scale of meter M2.

Functional test

4. (1) Set switch SC to position 7, switch on the supplies and ensure that lamps LP1 and LP4 are illuminated.
- (2) Set switch SA to position 3, operate switch SG and ensure that the lamp LP2 is illuminated.
- (3) Release switch SG and ensure that lamp LP2 is extinguished.

Input current consumption test

5. (1) Set switch SB to position 2. 
- (2) The standby input current now indicated on meter M1 on the 0-20mA scale should be not more than 8.5mA. (if the indication is not greater than 5mA press switch SD and read meter M1 on the 0-5 scale).
- (3) Set switch SB to position 3, lamp LP2 is  illuminated.
- (4) The operating input current then indicated on meter M1 should be not more than 14.5mA.

Relay current test

6. (1) Set switch SB to position 4, rotate the resistance control RV1 clockwise to the point where lamp LP2 is illuminated.
- (2) The relay operating current then shown on meter M1 should be between 13-17mA.
- (3) Return resistance control RV1 to the point where lamp LP2 is extinguished.
- (4) The relay release current then shown on meter M1 should be between 6-10mA.
- (5) Set resistance control RV1 fully counter-clockwise and switch SB to position 5.
- (6) The maximum relay current (short circuit detector) shown on meter M2 should be between 25-35mA.
- (7) Return switches SA, SB and SC to position 1, switch off both the 24V and 115V supplies and remove the unit from the test set.

Insulation resistance test

7. The insulation resistance of the relay unit may be measured using a 250V insulation resistance tester. A reading obtained when measuring between each contact button and the casing should be not less than 20 megohms.

RESTRICTED

This file was downloaded
from the RTFM Library.

Link: www.scottbouch.com/rtfm

Please see site for usage terms,
and more aircraft documents.

