

Chapter 5

CONSTANT FREQUENCY A.C. SYSTEM FAULT SIMULATOR
TEST SET

LIST OF CONTENTS

	<i>Para.</i>		<i>Para.</i>
<i>Introduction</i>	1	<i>Over voltage</i>	11
Description		<i>Line to earth fault</i>	12
<i>General</i>	4	<i>Over voltage discrimination during parallel operation</i>	13
<i>Case</i>	5	<i>Under voltage discrimination during parallel operation</i>	14
<i>Test leads</i>	6	Servicing	
Operation		<i>General</i>	15
<i>Single channel</i>	7	<i>Calibration</i>	16
<i>Parallel channel</i>	8	<i>Initial procedure</i>	17
Principles of tests			
<i>Under voltage</i>	10		

LIST OF ILLUSTRATIONS

	<i>Fig.</i>
<i>Test set</i>	1
<i>Test panel</i>	2
<i>Circuit diagram</i>	3

LEADING PARTICULARS

Test set	Ref. No. 5G/3759
<i>Overall dimensions (ins.)</i>	$17\frac{1}{2} \times 13\frac{1}{2} \times 9\frac{3}{8}$
<i>Weight</i>	28 lbs.

Introduction

1. The fault simulator test set enables the protection circuits associated with the 40kVA constant frequency generating system fitted to the Vulcan B Mk.2 and Victor B Mk.2 aircraft to be functionally tested during an engine ground run. Over voltage faults and under voltage faults are simulated by variation of the a.c. generator field excitation by the use of variable resistors. Line to earth faults are simulated by connecting a fixed resistor between the a.c. output and earth.

2. The test set is designed to be connected to the aircraft via test points, these are provided under Command modification procedure.

3. The test set is primarily intended for testing the protection circuits during aircraft periodic servicing. It can also be used for checking the protection circuits after rectification of faults associated with these circuits.

RESTRICTED

DESCRIPTION

General

4. The test set (fig. 1) consists of a front panel assembly and test leads housed in a wooden case. The front panel, which is of aluminium alloy, is fitted with six fuses, one volt meter, two rotary switches, two toggle switches, two variable resistors and a Mk.4 fixed socket, and is secured to battens in the wooden case by four wood screws. Fitted to the underside of the front panel are two aluminium brackets on which are mounted two standard single plugs and the Merz Price protection circuit resistors respectively. Handles are fitted to the front panel assembly to facilitate the removal of the assembly for servicing.

Case

5. The wooden case has a removable lid and is fitted with two snap fasteners and a leather carrying handle. Cooling grilles are fitted to the right-hand and undersides of the case to permit cooling of the resistors. On the left-hand side of the case is a plug to provide connection for the test leads.

Attached to the lid are operating instructions and a wiring diagram of the test set.



Fig. 1. Test set

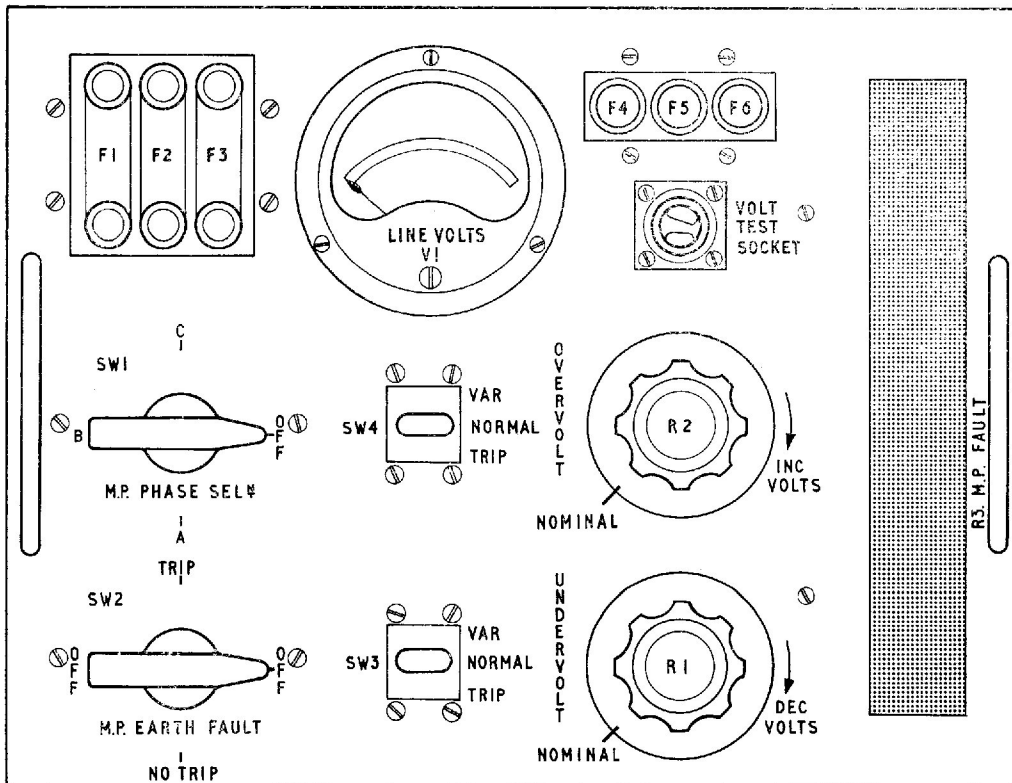

Fig. 2. Test panel

RESTRICTED

Test leads

6. The two test leads are of unipren cable, both ends of the cables terminate in standard single sockets. During use one end is connected to the test set and the opposite end to the aircraft test point. The individual conductors are connected between socket poles bearing corresponding figures or letters, i.e. 1-1 and A-A etc. When not in use the test leads are stowed in a cable compartment fitted to the test set lid.

OPERATION**Single channel**

7. To make a functional test of the protection circuits on a single channel, the test set is initially connected to the appropriate test point on the aircraft. The aircraft engine is then ground run at 5000 rev/min and the a.c. generator is switched on line. Variable and direct fault simulations are then applied to the channel under test by operation of the selector switches and variable resistors fitted to the test set. The generating system is then observed for correct operation, operating characteristics of over voltage and under voltage conditions being indicated by the volt meter.

Parallel channels

8. To make a functional test of the protection circuits associated with parallel operations, the aircraft engine of a second channel is ground run at 5000 rev/min and its a.c. generator switched on line. This a.c. generator is then paralleled with the a.c. generator of the channel under test and a load of 40kVA, 0.8 P.F. connected to the bus-bars. Variable over voltage and under voltage excitation faults are then applied to the channel under test by operation of the selector switches and variable resistors fitted to the test set. The generating system is then observed for correct operation as indicated by the instrumentation at both the test set and the A.E.O.'s control panel.

9. The aircraft test procedure will be contained in the relevant aircraft handbook.

PRINCIPLES OF TESTS**Under voltage***Direct fault simulation*

10. (1) This test interrupts the field winding of the a.c. generator exciter. The re-

sulting decrease in a.c. line voltage is sensed by the under voltage torque switch with subsequent tripping of the exciter relay and shut down of the a.c. generator.

Variable fault simulation

(2) During this test a 32ohm variable resistor is inserted in series with the field winding of the a.c. generator exciter. Increase of the resistance results in a decrease of field excitation and a fall of a.c. line voltage. The decrease in line voltage is sensed by the under voltage torque switch and, at a predetermined value, results in the tripping of the exciter relay and shut down of the a.c. generator. The operating value is indicated at the voltmeter.

Over voltage*Direct fault simulation*

11. (1) This test interrupts one phase of the 200V, 3-phase input to the voltage regulator resulting in a decrease of voltage applied to the operating coil of the regulator, compression of the carbon pile, increase in field excitation and increase in a.c. line voltage. The increase in line voltage is sensed by the over voltage trigger tube with subsequent tripping of the exciter relay and shut down of the a.c. generator.

Variable fault simulation

(2) This test inserts a 750ohm variable resistor in series with one phase of the 200V, 3-phase input to the voltage regulator, increase of this resistance results in a decrease of voltage applied to the operating coil of the regulator, compression of the carbon pile, increase in field excitation and consequent increase in a.c. line voltage. This increase in line voltage is sensed by the over voltage trigger tube and, at a predetermined value, results in the tripping of the exciter relay and shut down of the a.c. generator. The operating value is indicated by the volt-meter.

Line to earth fault*Trip*

12. (1) This test inserts a 2.3ohm resistor between the selected line and neutral, resulting in an out of balance circulating

RESTRICTED

current in the Merz Price protection circuit. This predetermined out of balance current, is sufficient to operate the differential relay associated with the selected line, with subsequent tripping of the exciter relay and shut down of the a.c. generator.

No trip

(2) This test inserts a 3.3ohm resistor between the selected line and neutral, resulting in an out of balance circulating current in the Merz Price protection circuit. This predetermined out of balance current is not sufficient to operate the differential relay associated with the selected line and the a.c. generator remains on line.

Over voltage discrimination during parallel operation

13. During this test a 750ohm variable resistor is inserted in series with one phase of the 200V, 3-phase input to the voltage regulator. Increasing the value of this resistance results in a decrease of voltage applied to the operating coil of the regulator and consequent compression of the carbon pile, thus producing an increase in field excitation, a rise in a.c. line voltage and an increase in reactive load. The associated mutual reactor increases the voltage applied to the over voltage trigger tube and, at a predetermined value, results in the tripping of the exciter relay and shut down of the a.c. generator. The out of balance reactive load which produces this effect is indicated as a value of voltage at the voltmeter.

Under voltage discrimination during parallel operation

14. During this test a 32ohm variable resistor is inserted in series with the field winding of the a.c. generator exciter. Increasing the value of this resistance results in a reduction in field excitation followed by a decrease in a.c. line voltage and consequent reduction of reactive load. The associated mutual reactor of the faulty channel reduces the voltage applied to the under voltage torque switch and, at a predetermined value, results in the tripping of the exciter relay and shut down of the a.c. generator concerned. The out of balance reactive load which produces this operation is indicated as a value of voltage at the volt-meter.

SERVICING

General

15. Routine servicing is restricted to examination of test set components for security of connections, overheating of resistances and signs of damage or deterioration of the test leads.

Calibration

16. To ensure serviceability of the test set before use on the aircraft, the following continuity tests should be made using a multimeter Type 12889 (Ref. No. 5QP/17447) or similar type of instrument.

Initial procedure

17. Ensure that all switches are set to OFF or NORMAL as appropriate, and that all variable resistors are set to NOMINAL.

Plug 1

18. (1) Connect the test meter between pins 1 and 4 and ensure that there is no continuity.
- (2) Set switch SW1 to PHASE A.
- (3) Set switch SW2 to TRIP, the resistance indicated by the test meter should be 2.3ohms.
- (4) Set switch SW2 to NO TRIP, the resistance indicated on the test meter should be 3.3ohms.
- (5) Set switch SW2 to OFF, the test meter should indicate that there is no continuity.
- (6) Connect the test meter between pins 2 and 4 and ensure that there is no continuity.
- (7) Set switch SW1 to PHASE B.
- (8) Repeat the operations described under (3) to (5) inclusive.
- (9) Connect the test meter between pins 3 and 4 and ensure that there is no continuity.
- (10) Set switch SW1 to PHASE C.
- (11) Repeat the operations described under (3) to (5) inclusive.
- (12) Set switch SW1 to OFF and disconnect the test meter.

Plug 2

19. (1) Connect the test meter between pins A and C and ensure that there is no resistance indicated by the test meter.

RESTRICTED

- (2) Set switch SW4 to TRIP and ensure that no continuity is indicated by the test meter.
- (3) Set switch SW4 to VAR and rotate R2 from the minimum resistance to the maximum resistance position. The resistance, as indicated by the test meter, should vary between 0 and 750ohms.
- (4) Set switch SW4 to NORMAL and ensure that the test meter indicates no resistance.
- (5) Connect the test meter between pins B and D and ensure that the test meter indicates no resistance.

- (6) Set switch SW3 to TRIP and ensure that the test meter indicates that there is no continuity.
- (7) Set switch SW3 to VAR and rotate R1 from the minimum resistance to the maximum resistance position. Ensure that the resistance, as indicated by the test meter, varies between 0 and 32ohms.
- (8) Set switch SW3 to NORMAL and ensure that the test meter indicates no resistance.
- (9) Disconnect the test meter.

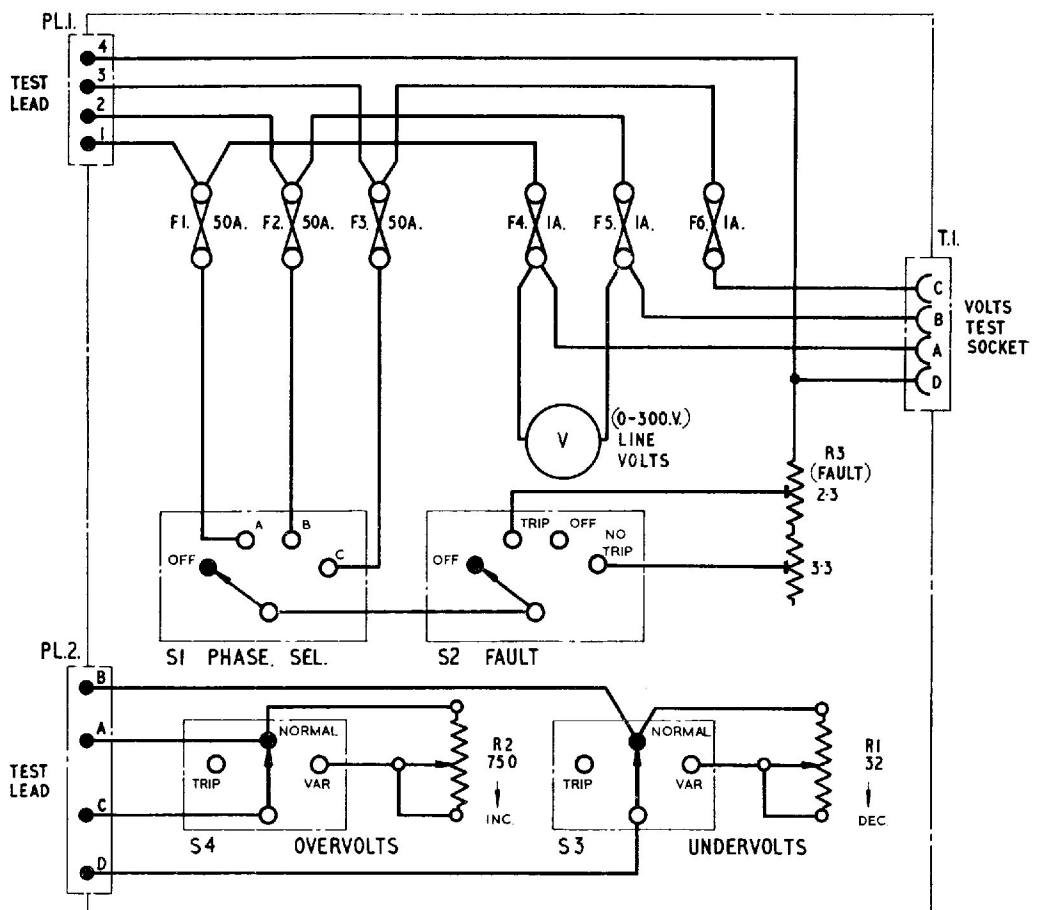

Fig. 3. Circuit diagram

RESTRICTED



This file was downloaded
from the RTFM Library.

Link: www.scottbouch.com/rtfm

Please see site for usage terms,
and more aircraft documents.

