

2nd Edition
October, 1957

M
RESTRICTED
202
10th

A.P. 4360A—P.N.

PILOT'S NOTES

SEA VENOM

F.A.W. 20

M
202



Prepared by Direction
of the
Minister of Supply

Promulgated by Command
of
Their Lordships

R. Musgrave

J. G. Lang

RESTRICTED

RESTRICTED

NOTES TO USERS

These Notes are complementary to A.P.129 (6th Edition), Flying, and it is assumed that all concerned have a thorough knowledge of the chapters which are relevant to the operation of this type of aircraft.

Additional copies may be obtained from Head of Military Branch (Books), Admiralty Block C, Station Approach Buildings, Kidbrooke, by application on Royal Navy Form S134D or D397. The number of the publication must be quoted in full—A.P.4360A—P.N. (2nd Edition).

Comments and suggestions should be forwarded through the usual channels to the Admiralty (D.A.W.).

AMENDMENTS

Amendment Lists will be issued as necessary and will be gummed for affixing to the inside front cover of these Notes. Each amendment list will, where applicable, be accompanied by gummed slips for sticking in the appropriate places in the text. Incorporation of an amendment list must be certified by inserting the date of incorporation and initials below.

A.L. No.	INITIALS	DATE	A.L. No.	INITIALS	DATE
1			4		
2			5		
3			6		

RESTRICTED

SEA VENOM F.A.W. 20

LIST OF ASSOCIATED PUBLICATIONS

<i>Title</i>	<i>A.P. No.</i>
Sea Venom F.A.W. 20, general and technical information	4360A Vol. 1
Ghost Mk.10300 series E.C.U.	4320A
Fuel system components for gas turbine aero engines	4282 series
Electrical equipment manual	1095 series 4343 series
Starting systems for aero engines	1181 series
Aircraft hydraulic equipment—Lockheed ..	1803B
Aircraft undercarriage equipment—Lockheed	1803C
Aircraft pneumatic equipment, Hymatic ..	4303C
Aircraft pressurising and air conditioning equipment	4340
Aircraft wheels, tyres, and brakes	2337
R.A.F. signals manual	1186 series
Instrument manual	1275 series
Safety equipment	1182 series
Cine-cameras and accessories	1355D
Hispano 20 mm guns	1641F
Air pump units	1519

SEA VENOM F.A.W. 20

LIST OF CONTENTS

	Page
Notes to users	1
List of associated publications	1
Frontispiece	2
Fuel system diagram	8
Hydraulic system diagram	14
Flying controls locking gear	18
Cockpit pressurisation and heating diagram	27
Cruise data charts	78-79
R.A.T.O. chart	81

PART I—DESCRIPTIVE

	Para.
Introduction	1

FUEL AND OIL SYSTEMS

Fuel tanks	2
Fuel contents gauge	3
Fuel transfer system	4
Booster pump	5
L.P. cock	6
Wing-tip tanks fuel jettison switch	7
Oil system	8

ENGINE CONTROLS

Ghost Mk. 103 engine	9
Starting system	10
Relighting control	11
Engine instruments	12
Engine fire-warning light and extinguishers	13

MAIN SERVICES

Hydraulic system	14
Pneumatic system	15
Electrical system	16

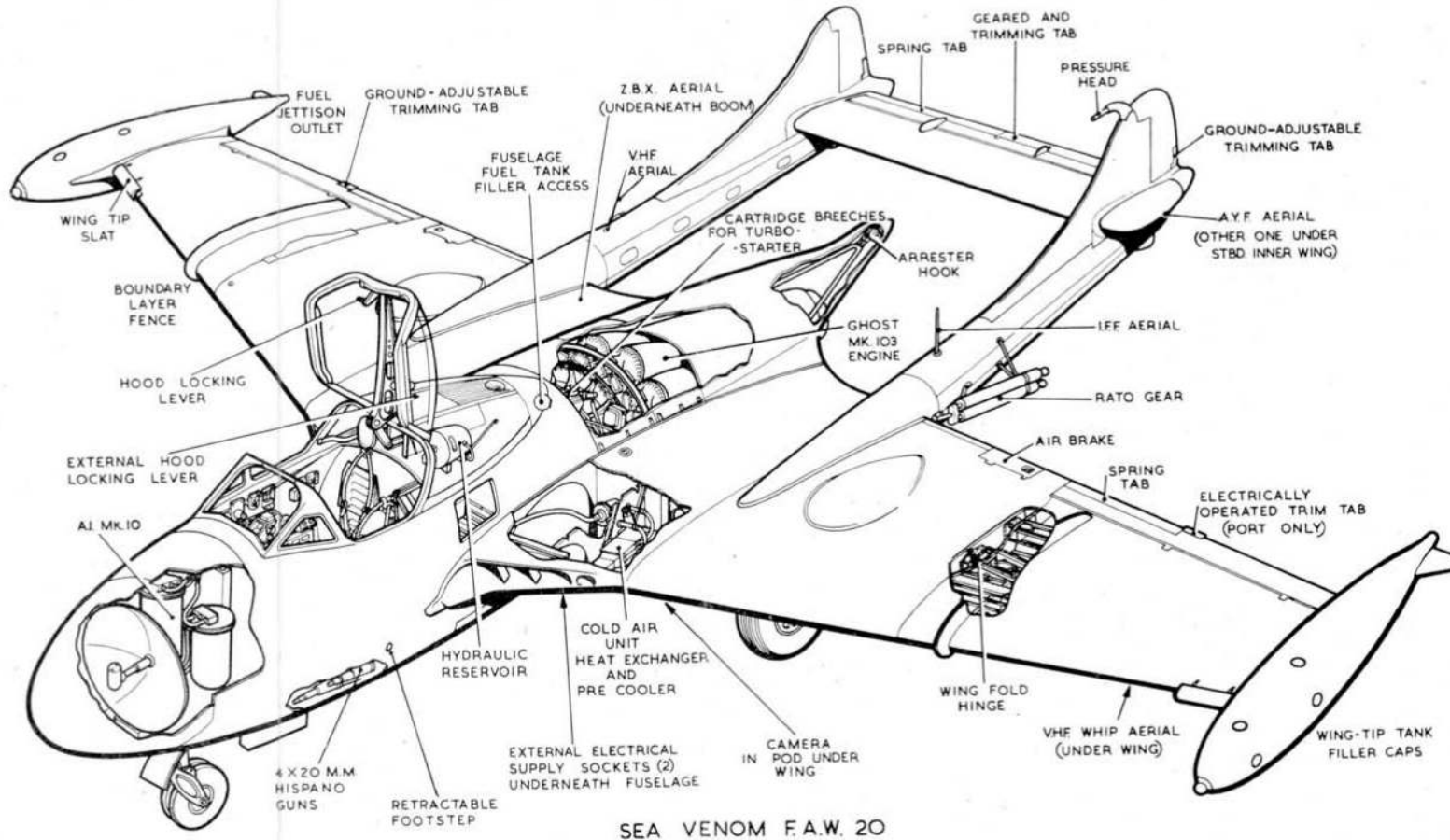

AIRCRAFT CONTROLS

	<i>Para.</i>
Flying controls	17
Trimming controls	18
Flying controls locking gear	19
Undercarriage	20
Flaps	21
Airbrakes	22
Arrester hook	23
Wheel brakes	24
Wing folding and spreading	25
Mach number warning device	26
R.A.T.O.G.	27
Flight instruments	28

COCKPIT EQUIPMENT

Access to cockpit	29
Hood operation	30
Hood jettisoning	31
Oxygen system and pressure-breathing equipment	32
Cockpit air conditioning	33
Windscreen de-icing	34
Direct-vision panel	35
Windscreen wiper	36
Anti-G equipment	37
Seat, headrest and harness adjustment	38
Internal lighting	39
External lighting	40

RADIO AND RADAR

V.H.F. (A.R.I.5491)	41
Z.B.X. (Homing beacon receiver)	42
Intercomm.	43
A.I. 10 (Search radar)	44
I.F.F.	45

ARMAMENT EQUIPMENT

Gunsight	46
Cameras	47
Guns	48
Rockets	49

PART II—LIMITATIONS

Engine limitations—Ghost Mk. 103	50
Flying limitations	51
General limitations	52

PART III—HANDLING

MANAGEMENT AND USE OF SYSTEMS *Para.*

Management of the fuel system	53
Engine handling	54
Management of the pressurising and demisting systems	55
Management of the electrical system	56
Management of the wing-fold mechanism	57

STARTING, TAXYING AND TAKE-OFF

External checks	58
Internal checks	59
Checks before starting	60
Starting the engine	61
Checks after starting	62
Taxyng	63
Checks before take-off	64
Take-off	65

HANDLING IN FLIGHT

Climbing	66
Flying controls	67
Night flying	68
Flying for endurance	69
Flying at reduced speed	70
Flying in conditions of severe turbulence	71
Stalling	72
Spinning	73
High speed flying	74
Aerobatics	75
Descent	76

CIRCUIT PROCEDURE AND LANDING

Checks before landing	77
Approach and landing	78
Instrument approach	79
Flapless landing	80
Cross-wind landing	81
Checks after landing	82
Shut-down procedure	83

PART IV—EMERGENCY HANDLING

	<i>Para.</i>
Action in the event of engine failure in flight	84
Relighting	85
Action in the event of the throttle jamming open	86
Action in the event of engine fire	87
Action in the event of hydraulic failure	88
Undercarriage emergency retraction	89
Action in the event of electrical failure	90
Action in the event of cockpit pressure failure	91
Action in the event of oxygen failure	92
Landing with a full tip tank on one side	93
Hood jettisoning	94
Forced landing	95
Abandoning the aircraft	96
Ditching	97

PART V—OPERATING DATA

Loading and C.G. data	98
Pressure error correction	99
Fuel consumptions	100
Take-off distances	101
Flight planning data	102
Endurance	103
Use of the R.A.T.O. chart.. .. .	104

PART VI—ILLUSTRATIONS

	<i>Fig.</i>
Cockpit—port side	1
Cockpit—forward view	2
Cockpit—starboard side	3

This file was downloaded from the RTFM Library.
Link: www.scottbouch.com/rtfm

Please see site for usage terms, and more aircraft documents.

