

30

RESTRICTED

AIR PUBLICATION

4377A

VOLUME 1
BOOK 3

SECT. 5, CHAP. 6 TO 9

SECT. 6 AND 7

TECHNICAL LIBRARY
COPY NO. FOUR



VALIANT B Mk. 1, B/PR Mk. 1, B/K Mk. 1
AND B/K/PR Mk. 1 AIRCRAFT

ELECTRICAL, INSTRUMENT, RADIO
AND ARMAMENT INSTALLATIONS

Prepared by direction of
the Minister of Supply

R. Musgrave

Promulgated by Command
of the Air Council

H. J. Dean

AIR MINISTRY

THE PATENT 'LOXON' LOOSE-LEAF BINDER

Patent No. 700547
Prov. Patent No. 22808/55



LIST OF STANDARD SIZES

Ref. No.	Size of leaf
51	8 x 6½
52	9 x 7
53	10 x 8
55	13 x 8

Reference and
Quality

F 3140

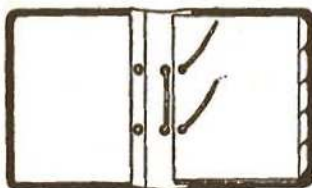

HOW TO USE

To add leaves to the front, merely disconnect the tags and withdraw laces from the flange.

To insert or withdraw leaves at any point without the leaves being freed from the control of the laces at any time:—



Unhitch the laces from the spiral springs, unthread the laces from the flange and join together the two ends of each lace thus forming two separate loops.



Draw the tags through to the required place, disconnect, insert or remove sheets.

Always have the laces free from the springs when the book is in use.

HUNT & BROADHURST LTD., OXFORD

AMENDMENT RECORD SHEET

To record the incorporation of an Amendment List in this publication, sign against the appropriate A.L. No. and insert the date of incorporation

A.L. No.	Amended by	Date
1	W. Morgan	10-9-57
2	Chilton	3-2-57
3	H. Jones	4-11-57
4	H. Jones	27-7-59
5	H. Jones	8-10-55
6	H. Jones	22-5-59
7	L. H. Spt.	5-5-60
8	A. Barber	16-9-60
9	H. Jones	3-11-59
10	H. Jones	11-9-59
11	H. Jones	8-7-60
12	A. Barber	7-10-60
13	A. Barber	27-9-60
14	H. Jones	1-9-59
15	A. Barber	21-12-60
16	A. Barber	7-10-60
17	B. Wharton	4-6-61
18	B. Wharton	11-7-61
19	B. Wharton	1-5-61
20	H. Jones	12-6-61
21	B. Wharton	5-4-61
22	B. Wharton	26-4-61
23	H. Jones	13-6-61
24	NOT TO BE ISSUED	11-1-62

A.L. No.	Amended by	Date
25	B. Wharton	11-1-62
26	B. Wharton	9-8-61
27	B. Wharton	10-11-61
28	B. Wharton	6-12-61
29	B. Wharton	9-10-61
30	B. Wharton	6-12-61
31	B. Wharton	8-2-62
32	H. Jones	9-8-62
33	H. Jones	15-11-62
34	H. Jones	15-2-63
35	H. Jones	9-5-63
36	H. Jones	17-4-63
37	H. Jones	9-5-63
38	H. Jones	31-7-63
39	K. Handman	30-1-64
40	K. W. Chapman	25-4-64
41	J. M. Miller	9-12-64
42		
43		
44		
45		
46		
47		
48		

A.L. No.	Amended by	Date
49		
50		
51		
52		
53		
54		
55		
56		
57		
58		
59		
60		
61		
62		
63		
64		
65		
66		
67		
68		
69		
70		
71		
72		

(Continued overleaf)

(Issued Jan. 57)

RESTRICTED

A.L. No.	Amended by	Date
73		
74		
75		
76		
77		
78		
79		
80		
81		
82		
83		
84		
85		
86		
87		
88		
89		
90		
91		
92		
93		
94		
95		
96		
97		
98		
99		
100		

A.L. No.	Amended by	Date
101		
102		
103		
104		
105		
106		
107		
108		
109		
110		
111		
112		
113		
114		
115		
116		
117		
118		
119		
120		
121		
122		
123		
124		
125		
126		
127		
128		

A.L. No.	Amended by	Date
129		
130		
131		
132		
133		
134		
135		
136		
137		
138		
139		
140		
141		
142		
143		
144		
145		
146		
147		
148		
149		
150		
151		
152		
153		
154		
155		
156		

RESTRICTED

LETHAL WARNING

EJECTION SEATS AND CANOPY JETTISON MECHANISMS

1. Ejection seats and canopy jettison mechanisms are sources of potential danger to personnel and of damage to the aircraft. Serious injury (possibly fatal) may result if any firing mechanisms are inadvertently operated whilst the aircraft is on the ground.
2. The following instructions are to be obeyed :—
 - R.N.** Safety precautions contained in A.P.(N.)140—Naval Aircraft Maintenance Manual.
 - R.A.F.** **ALL PERSONNEL** before entering the cockpit or cabin of an aircraft fitted with an ejection seat are to report to the N.C.O. immediately in charge of Airframe servicing who is to ensure that all safety pins (or other safety devices) are correctly positioned to render the seat and canopy jettison firing mechanisms safe. On completion of servicing, tradesmen are to report to the N.C.O.
3. Full instructions for rendering the firing mechanisms safe are contained in the A.P.4288 and A.P.(N.)1023 series, in Aircraft Servicing Schedules and in the A.D.5037 series.
4. Voltages in excess of 100 volts either a.c. or d.c. can be dangerous under certain circumstances. Personnel should therefore ensure that the electrical system is electrically safe before any servicing is attempted. Where it is essential that tests or adjustments are to be made with the electrical power switched on, the greatest care must be exercised.
5. METHYL BROMIDE. Odourless non-irritant vapour highly poisonous. The effects may not be apparent at once and may be fatal if a large amount is inhaled before signs develop.
6. HIGH ENERGY IGNITORS. The energy stored in the capacitors of the high energy ignitors units can under certain circumstances be of a lethal nature. No servicing should be attempted until at least one minute has elapsed after disconnection of the L.T. supply to the input plug.
7. BOMB DOORS. It is important to note that even though the ISOLATOR switches are at ISOLATE and the TRIP SWITCH at NORMAL the doors WILL operate if the JETTISON switch be placed to JETTISON.

RESTRICTED

NOTE TO READERS

The subject matter of this publication may be affected by Air Ministry Orders, by Servicing schedules (Vol. 4) or by "General Orders and Modifications" leaflets in this A.P., in the Associated publications listed overleaf or even in some others. If possible, Amendment Lists are issued to correct this publication accordingly, but it is not always practicable to do so. When an Order, Servicing schedule or leaflet contradicts any portion of this publication, the Order, Servicing schedule or leaflet is to be taken as the overriding authority.

The inclusion of references to items of equipment does not constitute authority for demanding the items.

Each leaf bears the date of issue and, when applicable, the number of the Amendment List with which it was issued. New or amended technical information on new leaves which are inserted when this publication is amended will be indicated by solid triangles in the text.

The triangles are placed thus ◀ . . . ▶ to show the extent of amended matter and thus ▶◀ to show where text has been deleted. When a Section or Chapter is issued in a completely revised form, the triangles will not appear.

This Volume 1 is issued in three covers, and if more than one copy of the publication is held, each set of covers should be given a copy number and kept together.

RESTRICTED

LIST OF ASSOCIATED AIR PUBLICATIONS AND DIAGRAMS

	<i>A.P.</i>		<i>A.P.</i>
◀ <i>Aircraft pneumatic equipment</i>	4303 series	<i>Missile storage and procedures</i>	2852B
<i>Aircraft refuelling equipment</i>	4511	<i>Powered flying control units and equipment</i>	4603 A & B
<i>Aircraft refuelling in flight</i>	4611	<i>Pressurizing and air-conditioning equipment, aircraft</i>	4340
<i>Aircraft tanks</i>	4117A	<i>R.A.F. engineering</i>	1464 series
<i>Aircraft wheels, tyres and brakes</i>	2337	<i>Safety equipment</i>	1182▶
<i>A.R.I. 5378 and 5380</i>	2533 series		
<i>A.R.I. 5800</i>	2891H		<i>A.D.</i>
<i>A.R.I. 5810</i>	2894H	<i>Fuel system</i>	5601
<i>A.R.I. 5829</i>	2557G	<i>Hydraulic system</i>	5603
<i>A.R.I. 5848</i>	2887N	<i>De-icing systems</i>	5605
<i>A.R.I. 5851 and 5857</i>	2890R	<i>Cabin heating, ventilating and pressurizing systems</i>	5606
<i>A.R.I. 5874</i>	2535E	<i>Fire extinguisher system</i>	5608
<i>A.R.I. 5922</i>	2914AP	<i>Flying controls</i>	5609
<i>A.R.I. 5924</i>	2914AN	<i>Auto-pilot installation</i>	6565
<i>A.R.I. 18011</i>	2534E	<i>Emergency equipment</i>	5612
<i>A.R.I. 18064</i>	2528P	<i>Canopy jettison system and elevator disconnection</i>	5613
<i>A.R.I. 18089</i>	2876E	<i>Undercarriage actuation and locks</i>	5614
<i>A.R.I. 23051</i>	2883KD	<i>E.C.U. Installation connections</i>	5616
<i>Armaments</i>	1661 series	◀ <i>E.C.U. Oil circulation and gear trains</i>	6044
<i>Autostabilizer system Mk. 2</i>	1469S	<i>E.C.U. fuel system</i>	6041
<i>Avon Mk. 20101 series engine change unit</i>	4481A & D	<i>E.C.U. servicing information</i>	6042▶
<i>Bomb carriers and equipment</i>	1664 series	<i>Lubrication</i>	5618
<i>Ejection seats, R.A.F. aircraft, Mk. 3 series</i>	4288C	<i>Electrical installation B Mk. 1</i>	6359
<i>Electrical equipment manual</i>	4343 series	<i>Electrical installation B PR Mk. 1</i>	6514
<i>Fire prevention and fire extinguishing equipment</i>	957C	<i>Electrical Installation B K Mk. 1</i>	6572
<i>Hydraulic equipment, aircraft, Vickers</i>	1803N	◀ <i>Electrical installation B K PR Mk. 1</i>	6576▶
<i>Instrument manual</i>	1275 series	<i>Bomb gear installation</i>	5620

R E S T R I C T E D

LAYOUT OF A.P.4377A

VALIANT B Mk. 1, B/PR Mk. 1, B/KMk. 1 and B/K/PR Mk. 1, AIRCRAFT

*Heavy type indicates the books issued under this
A.P. number; when issued they will be listed in A.P. 113*

*VOLUME 1	General and Technical information
Book 1	Containing Sections 1 to 4
Book 2	Containing Sections 5, Chapters 1 to 5
Book 3	Containing Section 5, Chapters 6 to 9 and Sections 6 and 7
VOLUME 2	General Orders and Modifications
VOLUME 3	Equipment Schedules and Scales
Part 1	Schedule of Spare Parts
Part 2	Appendix "A"
Part 3	Scales of Unit Equipment
Part 4	Scales of Servicing Spares
VOLUME 4	Planned Servicing Schedules
VOLUME 5	<i>Basic Servicing Schedules (not applicable)</i>
VOLUME 6	Re-air and Reconditioning Instructions
P.N.	Pilot's Notes
G.H.N.	Ground Handling Notes
◀O.D.	Operating Data▶

**When demanding the Volume 1, state the individual Book number(s) required*

CONTENTS

Introduction			
Leading Particulars			
Section 1—Controls and Exits	Chapter	1—Pilot's Controls and Equipment
			2—Controls and Equipment at Crew Stations
			3—Emergency Controls, Equipment and Exits—Method of Operation
Section 2—Ground Handling and Preparation for Flight	Chapter	1—Ground Handling
			2—Preparation for Flight
			3—Loading and C.G. Data
			4—General Servicing
			5—Conversion to PR roles
			6—Conversion to Refuelling-in-flight roles
Section 3—Airframe	Chapter	1—Fuselage
			2—Main Plane
			3—Tail Unit
			4—Flying Controls
			5—Landing Gear
			6—Hydraulic System
			7—Pneumatic Systems—Door and canopy seals, H2S radar and T4 bombsight system
			8—Air Conditioning and Pressurisation System
			9—De-icing Systems and bomb bay heating
			10—Oxygen System
			11—Emergency Equipment
			12—Vacuum System (<i>Not applicable</i>)
			13—Air Cooling System for Electrical and Radar Equipment
			14—Flap Gearbox
			15—Dive brake Gearbox
Section 4—Power Unit Installation	Chapter	1—Power Unit
			2—Fuel and Nitrogen Systems
			3—Oil System (<i>Not applicable</i>)
			4—Coolant System (<i>Not applicable</i>)
			5—Fire Protection System
			6—Water-methanol System
			7—Rocket assisted take-off unit
Section 5—Electrical System and Instrument Installation	Chapter	1—Power Supplies
			2—Airframe Services
			3—Armament Services
			4—Engine Services
			5—De-icing and Pressurization Services
			6—Instrument Installation
			7—N.B.S. Installation
			8—Conversion to PR roles
			9—Conversion to Refuelling-in-flight roles
Section 6—Radio Installations	Chapter	1—Wireless Installations
			2—Radar Installations
Section 7—Armament Installation	Chapter	1—Pyrotechnics
Note.—The ultimate content of each book is indicated above. In some cases, Sections or Chapters designated for Book 3 are at present contained in Book 2. For actual contents refer to the relevant section marker cards.			2—R.A.T.O. Equipment
			3—Guns (<i>Not applicable</i>)
			4—Bombing Equipment

BOOK 1

BOOK 2

BOOK 3

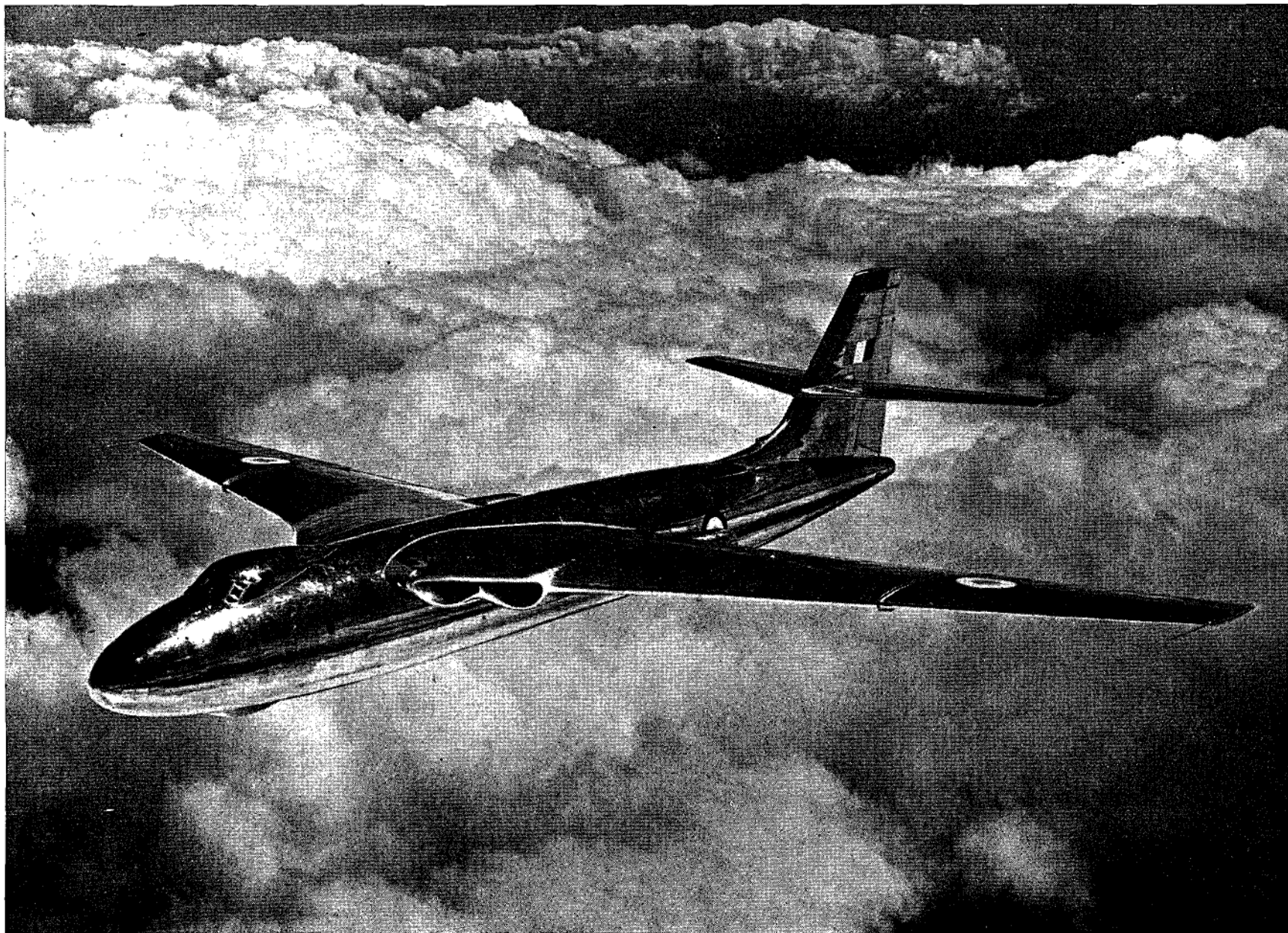

RESTRICTED

(Issued Jan. 57)

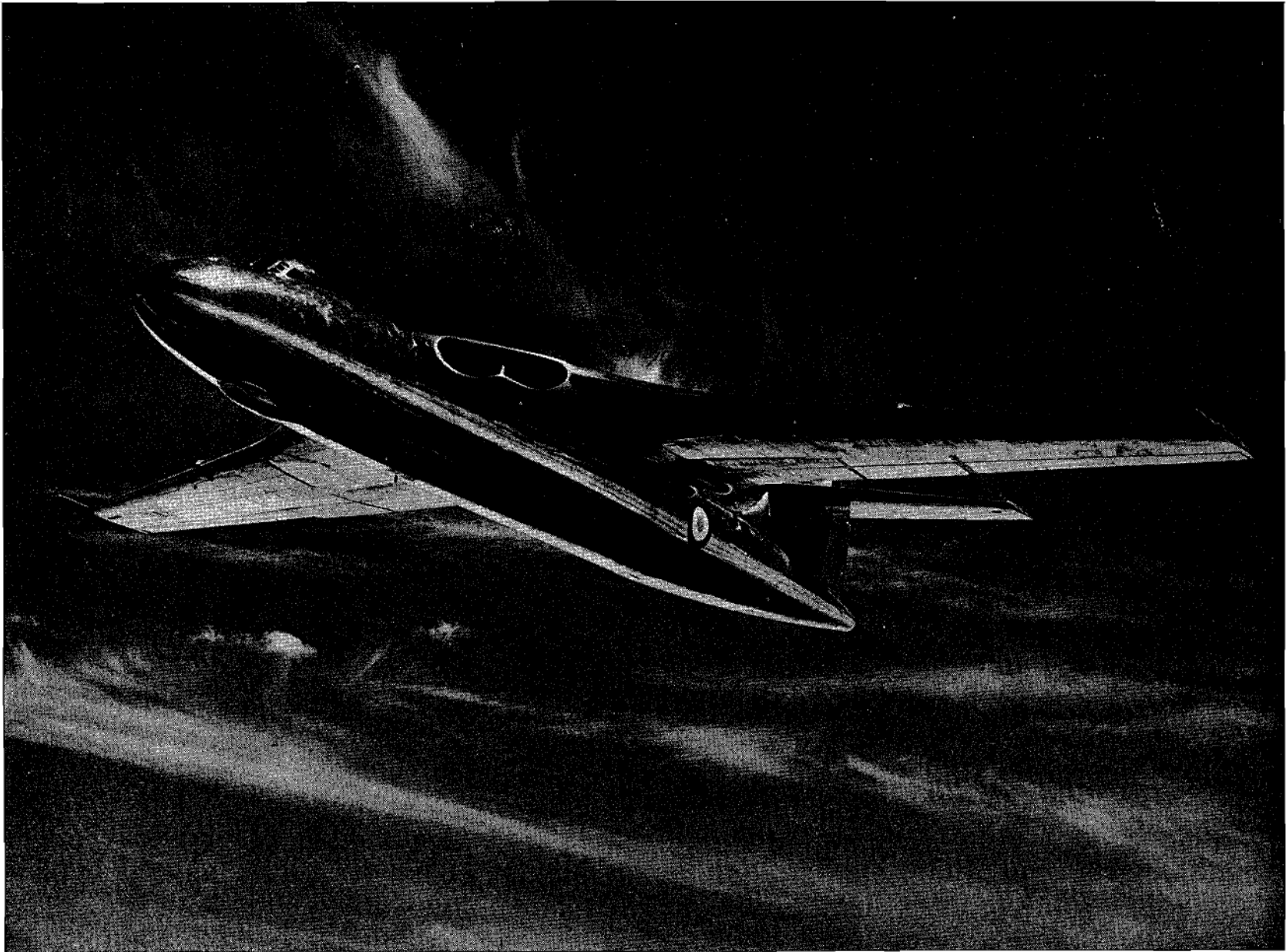

RESTRICTED

INTRODUCTION

The VALIANT aircraft is a high-wing monoplane of all-metal, stressed-skin construction. It is powered by four Rolls-Royce R.A.14 Avon turbo-jet engines and, basically, is a bomber, but certain aircraft are convertible to photographic reconnaissance or refuelling-in-flight roles. The crew of five, first and second pilot, two navigators and a wireless operator, are accommodated in a pressure cabin; the two navigators share the bomb-aiming and camera control duties. Ejection seats are fitted for both pilots. Provision is also made for carrying the servicing crew chief when necessary.

The fuselage is divided into three sections, the nose fairing, the pressure cabin and the main fuselage. With the exception of the nose fairing the structure is of high-tensile, light-alloy, stressed skin construction, flush-riveted externally. The skin plating is reinforced by closely spaced longitudinal stringers of lipped Z-section and bulb angle, and supported on lipped channel-section open frames. Only the stringers are attached to the skin, the frames being inside the stringers, to which they are cleated. Heavier built-up frames are provided in the region of the wing spar and tail unit attachments. The fuselage is of circular section throughout except for the slight blisters formed by the jettisonable canopy and the fairing in the region of the bomb-aimer's window.

The pressure cabin is that portion of the fuselage containing the crew, their controls and associated equipment. Reinforced bulkheads form the fore and aft boundaries respectively, the front bulkhead being convex and the rear concave. An elliptical door gives entry to the cabin on the port

side, and, with a hinged windshield forms the parachute exit. An elliptical window is provided on each side of the cabin, that on the starboard side being built into a crash exit. The sextant dome can be pulled in to form an emergency exit.

The main portion of the fuselage contains the nose wheel bay, the servicing bay, the rear bay, the bomb compartment, and the fuel tank bay. The fuel tank bay is above the bomb compartment, and, when the tanks are in position, has no means of entry.

The main plane is a cantilever, stressed-skin structure, swept back in two stages, the inner plane and the outer plane, the intersection of the two being faired in; thermal de-icing ducts are provided along the leading edge.

The inner plane, which carries the power plants, is of very short span; the two spars front and rear, are virtually built integral with the fuselage, the port and starboard spars being joined at the centre line of the fuselage by a fork joint and taper bolts. Flaps are fitted at the trailing edge and form part of the jet pipe outlets.

The outward-retracting main undercarriage units and the wing fuel tanks are carried in the outer planes and provision is made for carrying underwing tanks or stores. Slotted trailing-edge flaps are fitted from the inboard ends of the outer planes to the sealed, internally balanced ailerons which extend to the detachable wing tip. Dive brakes on the bottom surface extend across the inner half of the flap span.

The tail unit is of stressed-skin construction, and consists of a fin and rudder and a swept-back, variable-incidence tail plane to which conventional balanced elevators are fitted. The fin has a considerable dorsal extension forward and the rudder hinge line slopes backwards to the top. The tail plane is mounted high on the fin so as to be well above the jet streams. The leading edges of the fin and tail plane are equipped with thermal de-icing ducts, and the junction of the fin and tail plane is faired in.

The tricycle undercarriage consists of two main wheel units mounted in the outer planes, and a steerable nose wheel unit mounted in the fuselage just aft of the pressure cabin; each unit is lowered and retracted by an electric actuator, and when in the retracted position is totally enclosed by automatically-operated doors. The main wheel units each comprise two wheels supported by shock-absorber struts mounted in tandem and the nose wheel unit comprises twin wheels mounted on an axle which is supported centrally by a single shock-absorber strut. The nose wheel steering and main wheel braking are effected by electro-hydraulic power.

Side-by-side dual controls are fitted; the aileron, elevator and rudder circuits each incorporate, in a system of rigid push-pull rods, a power control unit and an artificial feel unit. In the event of the power supply failing, reversion to manual operation is automatic. When the canopy is jettisoned, the elevator controls are disengaged from the hand wheel, which is thrown forward to clear the pilot's legs when he is ejected.

RESTRICTED

(Issued Jan. 57)

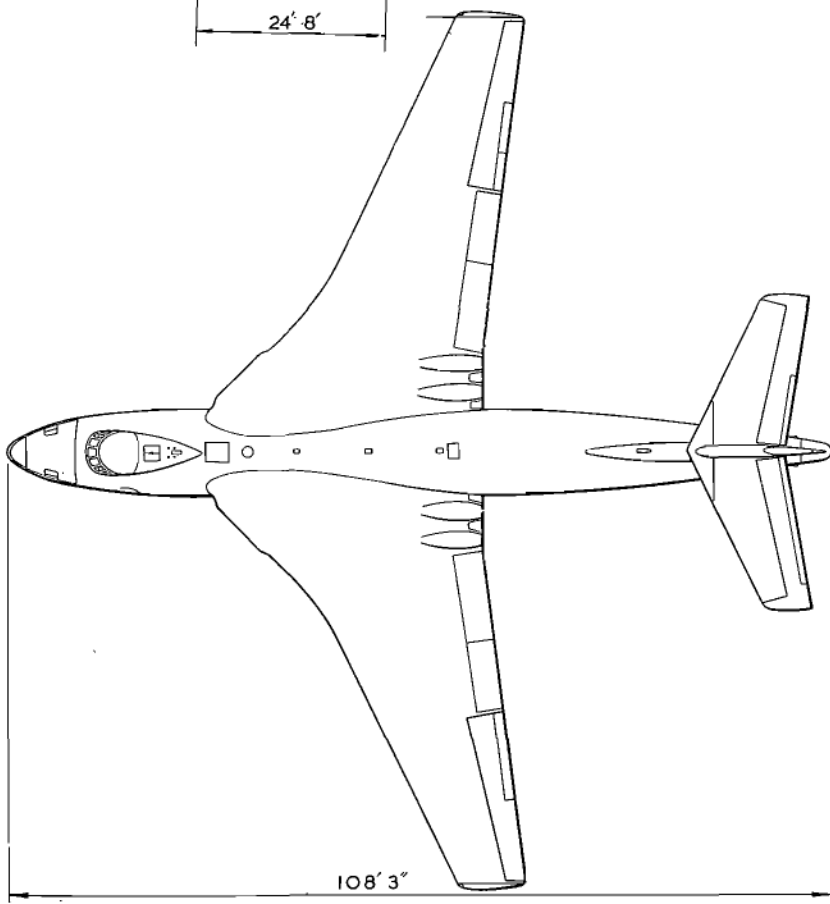
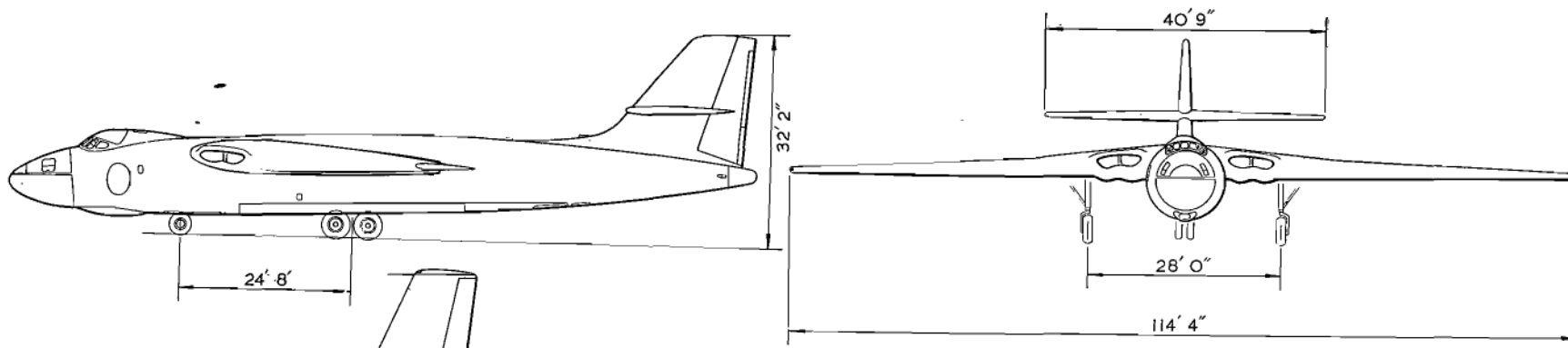

General arrangement

LEADING PARTICULARS

NAME VALIANT B Mk. I, B/PR Mk. I, B/K Mk. I and B/K/PR Mk. I
TYPE FOUR-ENGINE, HIGH-WING MONOPLANE
DUTY BOMBER
CREW FIVE—FIRST PILOT, SECOND PILOT, FIRST NAVIGATOR, SECOND NAVIGATOR, WIRELESS OPERATOR
CREW STATIONS SIX—INCLUDING BOMB-AIMER'S STATION

Principal dimension

The main dimensions of the Aircraft are quoted in the General Arrangement.

MAIN PLANE

Aerofoil section—at root Vickers, High Speed, 12% thickness/chord ratio
 at tip Vickers, High Speed, 9% thickness/chord ratio
Chord—at root 35.5 ft.
 at tip 8.5 ft.
Incidence—wing station 0 to 92 3 deg. 15 min. ± 15 min.
 wing station 240—outboard 2 deg. 15 min. ± 15 min.
Aileron chord 24 per cent. of local wing chord
Trailing edge flap chord 27 per cent. of local wing chord

Tail plane			
TAIL PLANE AND ELEVATOR—	<i>chord at root</i> 12.67 ft.
	<i>chord at tip</i> 6.14 ft.
INCIDENCE			
<i>Fixed portion</i> 0 deg.
<i>Variable-incidence portion</i> 3 deg. nose up to 5 deg. 15 min. nose down (Sect. 3, Chap. 4)
SWEEP BACK 25 deg. on 25 per cent. chord line

Areas			
MAIN PLANE, INCLUDING AILERONS—	<i>gross</i> 2,362 sq. ft.
	<i>nett</i> 1,962 sq. ft.
AILERONS, INCLUDING TABS—TOTAL 192.32 sq. ft.
AILERON TRIM TABS—TOTAL 19.11 sq. ft.
TRAILING EDGE FLAPS—TOTAL 374.16 sq. ft.
DIVE BRAKES 19 SQ. FT. EACH SIDE—TOTAL 38 sq. ft.
TAIL PLANE, INCLUDING STUBS AND ELEVATORS—GROSS 380.5 sq. ft.
ELEVATORS, INCLUDING TABS—TOTAL 146.7 sq. ft.
ELEVATOR TRIM TABS—TOTAL 5.97 sq. ft.
FIN, INCLUDING DORSAL EXTENSION AND RUDDER—GROSS 263 sq. ft.
DORSAL FIN EXTENSION 9.6 sq. ft.
RUDDER, INCLUDING TABS 92.5 sq. ft.
RUDDER TRIM TAB 3.11 sq. ft.
RUDDER BALANCE TAB 6.28 sq. ft.

ALIGHTING GEAR

Main wheel unit			
<i>Type</i> Tandem wheel, two struts, sideways retracting
<i>Track</i> 28 ft.
SHOCK-ABSORBER STRUTS			
<i>Type</i> Vickers oleo pneumatic
<i>Air pressure</i> Refer to Sect. 2, Chap. 2
<i>Fluid</i> Oil OM-15
WHEELS (TANDEM)			
<i>Type</i> Dunlop A.H.9811
<i>Tyres</i> Dunlop D.R.0521
<i>Inner tube</i> Dunlop D.T.0505
<i>Tyre pressures</i> Refer to Vol. 4 of this publication
BRAKES			
<i>Type</i> Dunlop hydraulic
<i>Operating pressures</i> 1,500 lb. per sq. in.

Nose wheel unit			
<i>Type</i> Twin wheel, single strut, fore-and-aft retracting steerable
SHOCK-ABSORBER STRUT			
<i>Type</i> Vickers' oleo pneumatic
<i>Air pressure</i> Refer to Sect. 2, Chap. 2
<i>Fluid</i> Oil OM-15
WHEELS (TWIN)			
<i>Type</i> Dunlop A.H.9861
<i>Tyre</i> Dunlop D.R.2665/1
<i>Inner tube</i> Dunlop K.C.3
<i>Tyre pressures</i> Refer to Vol. 4 of this publication
<i>Steering angle</i> 50 deg. each side

POWER UNIT

<i>Type</i> Avon E.C.U.20401 or 20501
ENGINES			
<i>Type</i> Turbo-jet
<i>Fuel</i> AVTAG
<i>Oil</i> DX-38

Fuel tank capacities (B. Mk. 1)

FUSELAGE TANKS			
<i>Reserve cells (295 gall. each cell)</i> 590±10 gall.
<i>No. 1 cells (367 gall. each cell)</i> 734±10 gall.
<i>No. 2 Cells (785 gall. each cell)</i> 1,370±10 gall.
<i>No. 3 Cells (643 gall. each cell)</i> 1,686±10 gall.
<i>Transfer tank</i> 710±10 gall.
WING TANKS			
<i>No. 1 tanks (553±10 gall. each side)</i> 1,106 gall.
<i>No. 2 tanks (473±10 gall. each side)</i> 946 gall.

◀ TOTAL FUEL—NORMAL ... 6,742 gall. ▶

◀ UNDERWING TANK (1,615±10 GALL. EACH SIDE) ... 3,230 gall. ▶

TOTAL FUEL—LONG RANGE ◀ 9,972 gall. ▶

Fuel tank capacities (B/PR, B/K and B/K/PR Mk. 1)

FUSELAGE TANKS			
<i>Reserve cells (295 gall. each cell)</i> 590±10 gall.
<i>No. 1 Cells (367 gall. each cell)</i> 734±10 gall.
<i>No. 2 Cells (685 gall. each cell)</i> 1,370±10 gall.
<i>No. 3 Cells (643 gall. each cell)</i> 1,286±10 gall.

RESTRICTED

Fuel tank capacities (B/PR, B/K and B/K/PR Mk. 1)—continued

Transfer tank	710±10	gall.
Bomb bay tank	575±10	gall.
WING TANKS							
No. 1 tanks (553±10 gall. each side)	1,106	gall.
No. 2 tanks (473±10 gall. each side)	946	gall.
TOTAL FUEL—NORMAL						7,317	gall. ▶
UNDERWING TANKS (1,615±10 GALL. EACH SIDE)						3,230	gall. ▶
TOTAL FUEL—LONG-RANGE						10,547	gall. ▶

Oil system

◀ SUMP CAPACITY	9½	pints
IN THE SYSTEM	2½	pints
						12	pints ▶

HYDRAULIC SYSTEM

ELECTRICALLY-OPERATED PUMPS

Pumps	Lockheed Mk. 7
Motors	Rotax, Type C.7601
CUT-IN PRESSURE	2,000 lb. per sq. in.
CUT-OUT RELIEF VALVE OPERATING PRESSURE	2,500 lb. per sq. in.
PRESSURE SWITCH—cut-in pressure	1,900 lb. per sq. in.
cut-out pressure	2,300 lb. per sq. in.
PRESSURE AT BRAKES	1,500 lb. per sq. in.
Fluid	Oil, OM-15

PNEUMATIC SYSTEM

Pressure in cylinder	450 lb. per sq. in.
----------------------	------	------	------	------	------	---------------------

ELECTRICAL SYSTEM

TYPE	112-volt and 28-volt d.c.
Wiring	Single-pole Pren cable, 112-volt engineered with S.B.A.C. connector blocks and 28-volt with Plessey connector blocks
GENERATORS (FOUR)	112-volt 22½ k.W., Type 551
Rotary transformers	112-volt/28-volt. 3 k.W., Type S3201
BATTERIES	Four 24-volt in series for 112-volt system and one 24-volt for 28-volt system
VOLTAGE REGULATORS						
112-volt system (four)	Type 91
28-volt system (three)	Type 66
DIFFERENTIAL RELAYS						
112-volt system (four)	Type 1A, No.1
28-volt system (three)	Type 2B

RADIO EQUIPMENT

Wireless

General purpose communications	A.R.I.5874
V.H.F. communications	A.R.I.18064
Intercommunication	A.R.I.18089
Radio compass	A.R.I.23051
I.L.S.	A.R.I.18011
Dinghy radio	T.3180 and Standard Kit No. 1
Radio altimeter	A.R.I.5380 or A.R.I.18090
Radio altimeter	A.R.I.5378

Radar

Navigational aid and bombing computator	A.R.I.5810
Navigational aid	A.R.I.5829 and A.R.I.5851 or A.R.I.5871
Tail warning	A.R.I.5800
I.F.F.	A.R.I.5848
Window	A.R.I.18051

DE-ICING SYSTEMS

WINDSCREEN

Tank capacity	4½	gall.
Fluid	A.L. 8	
Pumps (2)	◀ Dunlop A.C.13002 ▶	

BOMB AIMER'S WINDSCREEN

Tank capacity	2¼	gall.
Fluid	A.L. 8	
Pump	◀ Dunlop A.C.13000 ▶	

REFUELLING PROBE

Tank capacity	1	gall.
Fluid	A.L. 8	
Pump	◀ Dunlop A.C.13002 ▶	

ARMAMENT AND PYROTECHNICS

Cartridge, signal, 1½ in. (10)	(Ref. No. 12D/)
Cartridge, 1½ in. Mk. 1 (3)	(Ref. No. 12D/1211)
Detonator, canopy jettison (26)	No. 108,	Mk. 1	(Ref. No. 12G/1278)
◀ Cartridge, seat ejection, Sets No. 3	(Ref. No. 12K/1256) ▶
Cartridge, seat ejection, drogue	No. 1,	Mk. 1	(Ref. No. 12D/1171)
Cartridge, Type H operating head	(Ref. No. 12D/444)
Destructors, H.E., aircraft	No. 1,	Mk. 1	(Ref. No. 12L/203)
Signal distress. 2 star red, Mk. 4	(Ref. No. 12D/1113)
Bombs	See Sect. 2, Chap. 3

RESTRICTED

This file was downloaded
from the RTFM Library.

Link: www.scottbouch.com/rtfm

Please see site for usage terms,
and more aircraft documents.

