

Chapter 2
FUSELAGE

LIST OF ILLUSTRATIONS

	<i>Fig.</i>
<i>Main entrance door</i>	201
<i>Brake parachute release</i> <i>mechanism</i>	202

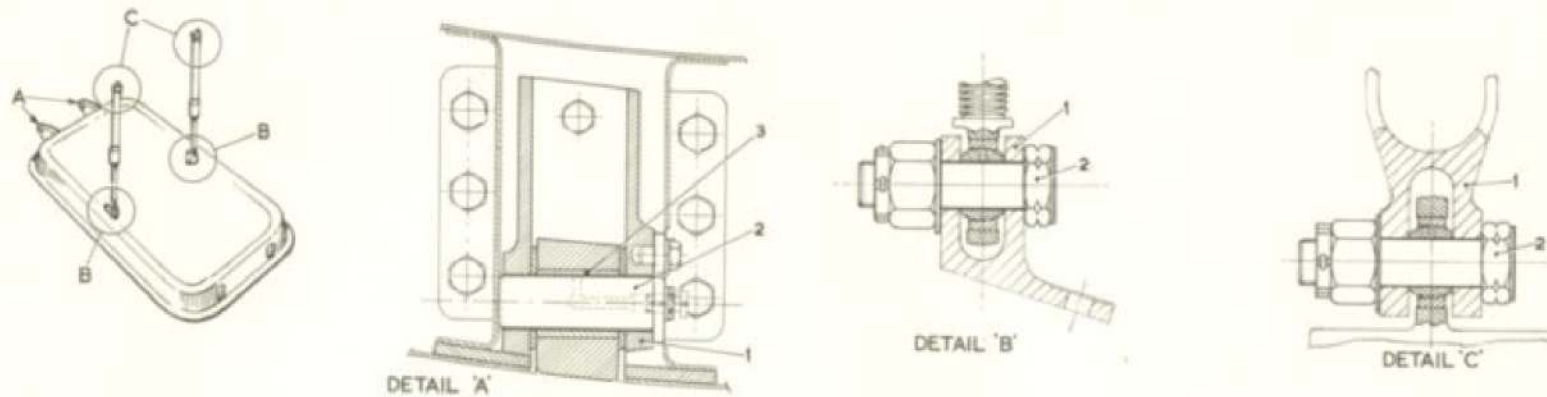

Fig.201. Main entrance door

Detail	Item	Part and Description	Permissible Worn Dimension (in.)			Clearance New (in.)	Permissible Worn Clearance (in.)	Remarks
			Dimension New (in.)	Non-selective Assembly	Selective Assembly			
A	1	BRACKET (bore)	$\frac{0.7505}{0.74975}$	0.751	0.752	$\frac{0.0025}{0.00075}$	0.003	
	2	PIN (o/dia.)	$\frac{0.749}{0.748}$	0.748	0.74675			
	3	BUSH (bore)	$\frac{0.75075}{0.74925}$	0.7515	0.7525	$\frac{0.00275}{0.00025}$	0.0035	
	2	PIN (o/dia.)	$\frac{0.749}{0.748}$	0.748	0.74575			
B	1	BRACKET (bore)	$\frac{0.5002}{0.4998}$	0.5008	0.50125	$\frac{0.0009}{0.00005}$	0.0015	
	2	BOLT (o/dia.)	$\frac{0.49975}{0.4993}$	0.4993	0.4983			
C	1	BRACKET (bore)	$\frac{0.5002}{0.4998}$	0.5008	0.50125	$\frac{0.0009}{0.00005}$	0.0015	
	2	BOLT (o/dia.)	$\frac{0.49975}{0.4993}$	0.4993	0.4983			

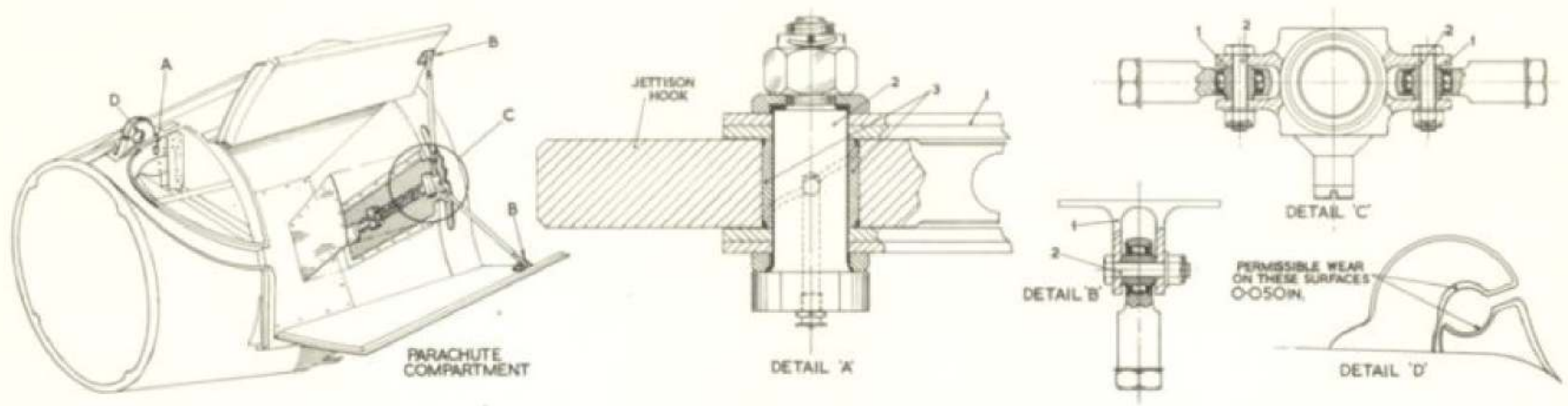

Fig.202. Brake parachute release mechanism

Detail	Item	Part and Description	Dimension New (in.)	Permissible Worn Dimension (in.)		Clearance New (in.)	Permissible Worn Clearance (in.)	Remarks
				Non-selective Assembly	Selective Assembly			
A	1	SIDE MEMBER (bore)	$\frac{1.00075}{0.9995}$	1.00125	1.00175	$\frac{0.0015}{-0.00025}$	0.002	
	2	BOLT (o/dia.)	$\frac{0.99975}{0.99925}$	0.99925	0.9975			
	3	BUSH (bore)	$\frac{1.00075}{0.9995}$	1.00125	1.00175	$\frac{0.0015}{-0.00025}$	0.002	
	2	BOLT (o/dia.)	$\frac{0.99975}{0.99925}$	0.99925	0.9975			
B	1	BRACKET (bore)	$\frac{0.188}{0.187}$	0.1888	0.18925	$\frac{0.0015}{-0.00025}$	0.002	
	2	BOLT (o/dia.)	$\frac{0.18725}{0.1868}$	0.1868	0.185			
C	1	BRACKET (bore)	$\frac{0.188}{0.187}$	0.1888	0.18925	$\frac{0.0012}{-0.00025}$	0.002	
	2	BOLT (o/dia.)	$\frac{0.18725}{0.1868}$	0.1868	0.185			

This file was downloaded
from the RTFM Library.

Link: www.scottbouch.com/rtfm

Please see site for usage terms,
and more aircraft documents.



LIGHTNING MK. 1
COVER PITOT HEAD
EB2-88-5111