

Chapter 4  
TAIL UNIT

LIST OF ILLUSTRATIONS

	<i>Fig.</i>
<i>Rudder hinges</i> ... ..	401

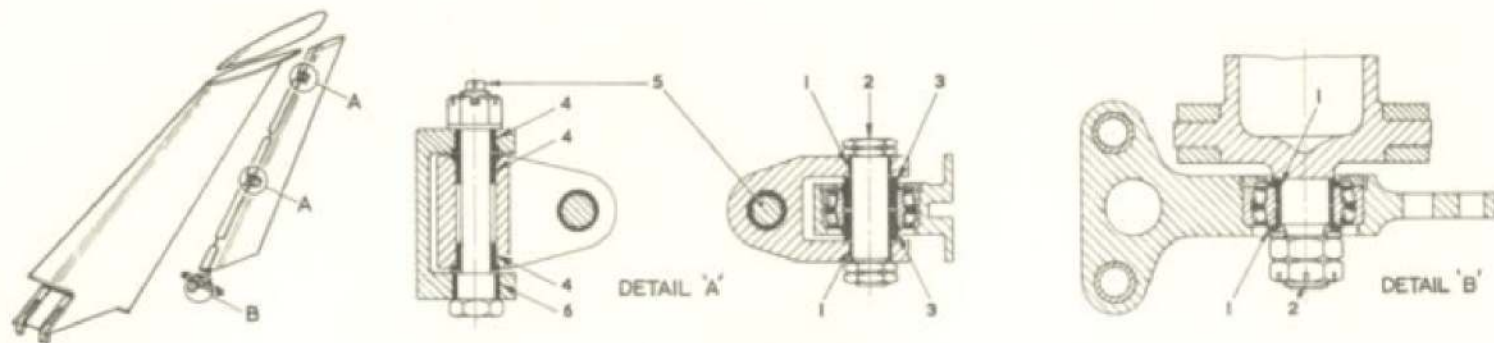

Fig.401. Rudder hinges

Detail	Item	Part and Description	Dimension New (in.)	Permissible Worn Dimension (in.)		Clearance New (in.)	Permissible Worn Clearance (in.)	Remarks
				Non-selective Assembly	Selective Assembly			
A	1	BUSH (bore)	$\frac{0.75075}{0.74950}$	0.75125	0.75275	$\frac{0.0035}{0.00075}$	0.004	
	2	BOLT (o/dia.)	$\frac{0.74875}{0.74725}$	0.74725	0.7455			
	3	BUSH (bore)	$\frac{0.7505}{0.74975}$	0.75125	0.75275	$\frac{0.00325}{0.001}$	0.004	
	2	BOLT (o/dia.)	$\frac{0.74875}{0.74725}$	0.74725	0.74575			
	4	BUSH (bore)	$\frac{0.62575}{0.6245}$	0.62625	0.62775	$\frac{0.0035}{0.00075}$	0.004	
	5	BOLT (o/dia.)	$\frac{0.62375}{0.62225}$	0.62225	0.6205			
	6	BUSH (bore)	$\frac{0.75075}{0.74950}$	0.75125	0.75275	$\frac{0.0035}{0.00075}$	0.004	
	5	BOLT (o/dia.)	$\frac{0.74875}{0.74725}$	0.74725	0.7455			
B	1	BUSH (bore)	$\frac{1.00075}{0.9995}$	1.001	1.0015	$\frac{0.0015}{-0.00025}$	0.00175	
	2	SHAFT (o/dia.)	$\frac{0.99975}{0.99925}$	0.99925	0.99775			

RESTRICTED

This file was downloaded  
from the RTFM Library.

Link: [www.scottbouch.com/rtfm](http://www.scottbouch.com/rtfm)

Please see site for usage terms,  
and more aircraft documents.



LIGHTNING MK. 1  
COVER PITOT HEAD  
EB2-88-511

A close-up photograph of a red aircraft fuselage. A grey fabric cover is draped over a section, with the text "LIGHTNING MK. 1", "COVER PITOT HEAD", and "EB2-88-511" printed on it. To the right, a rectangular metal plate is mounted on the red surface. The background shows the curved structure of the aircraft with several rivets.